

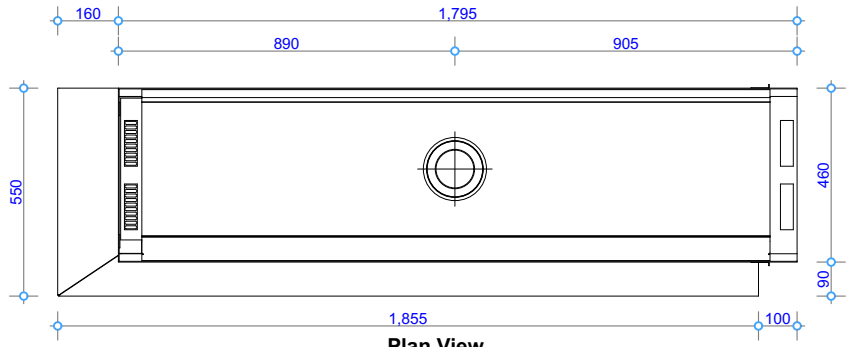

GD3 - 1600 Glass Left

Specifications

Information in this specification may be subject to change without notice. Please ensure you have the current version before beginning installation.



Plan View

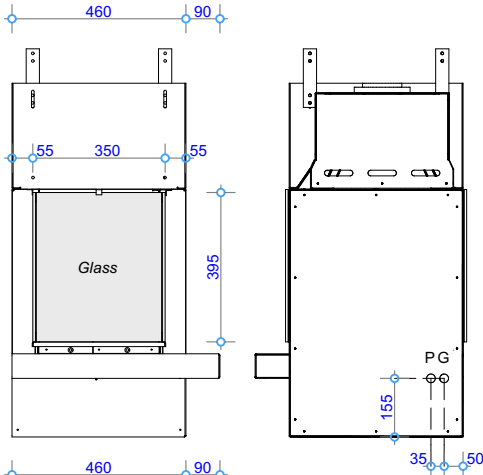

Side View

Side View

P = Power In
G = Gas In

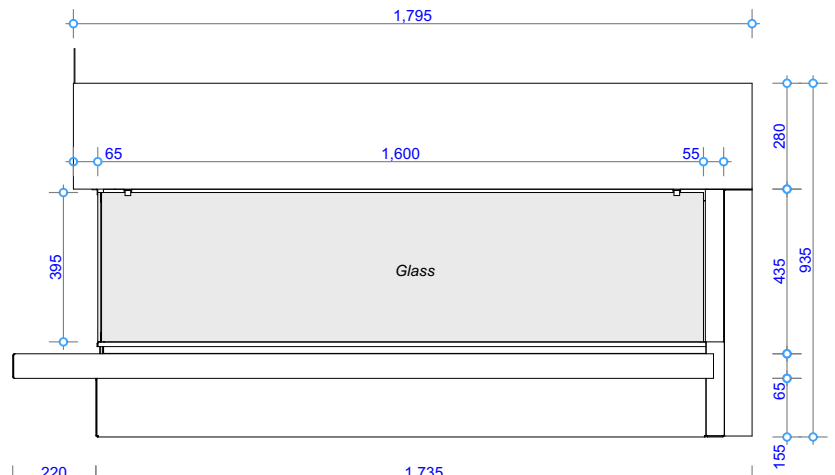

Front View

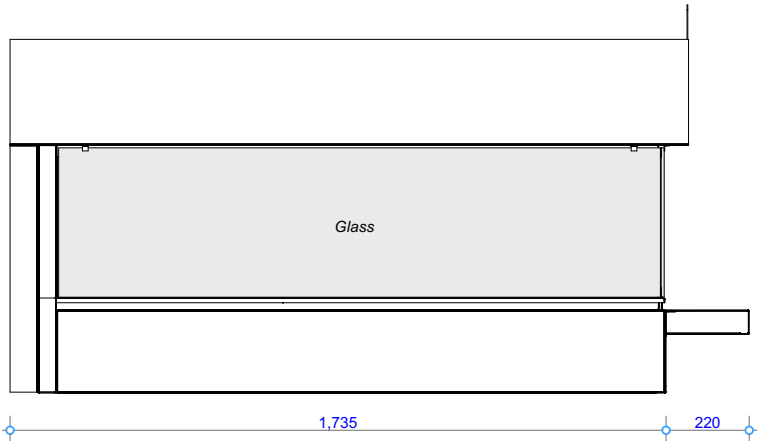

Rear View

TOLERANCE = +/- 3mm

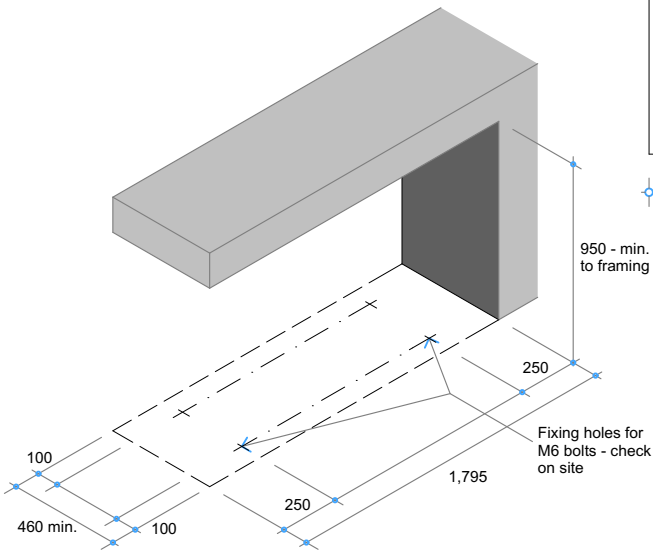

Fire Installation - Trim Sizes

NOTE: Confirm fixing holes on site prior to drilling

COPYRIGHT ©
THIS DRAWING IS THE PROPERTY
OF The Fire Dept.

Client: THE FIRE DEPT.		
Product: GD3-1600-GLASS LEFT		
Title: FIREBOX DIMENSIONS		
Drawn: SR	Date: 27/03/2018	
Chkd: JW	Date: 27/03/2018	
Appd: JW	Date: 27/03/2018	
Scale:		on A4



Drawing No.	GD3-1600-901L	Sheet 01 of 08	Revision 4
-------------	----------------------	----------------	-------------------

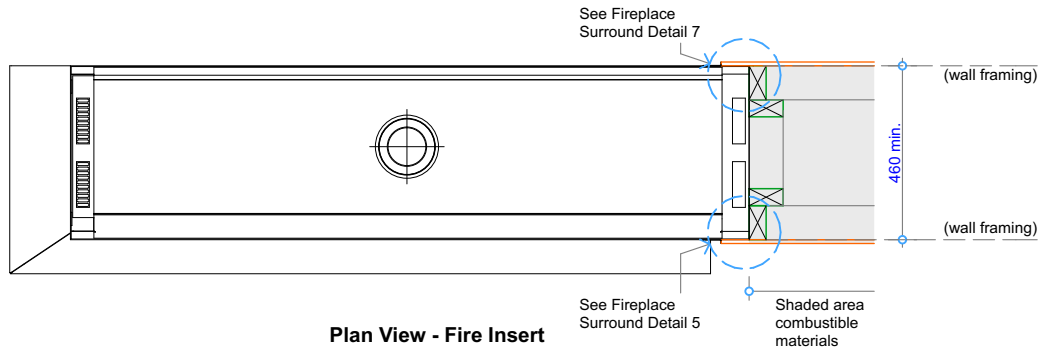

Plan View - Fire Insert

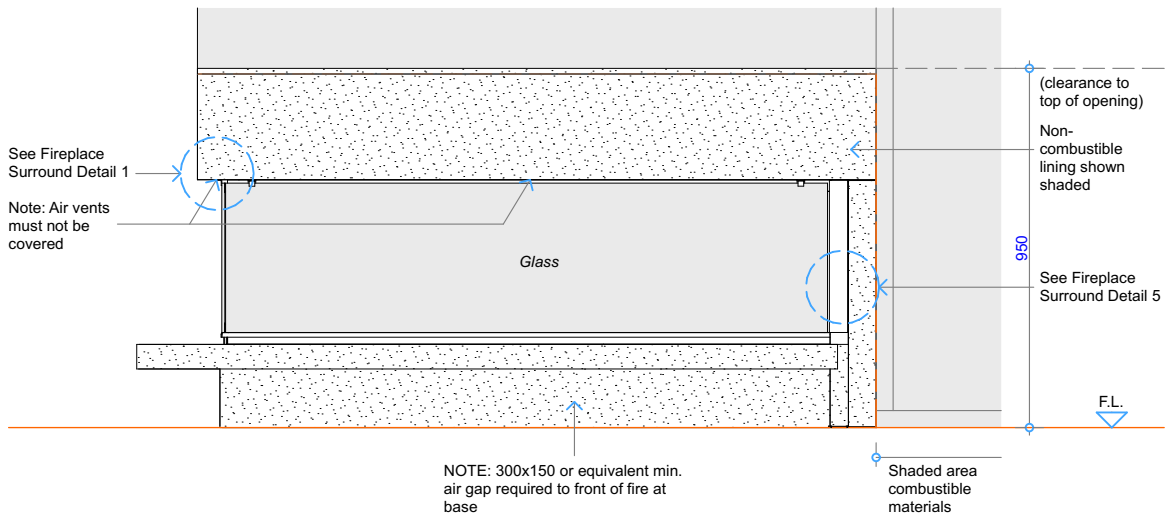

Front View - Fire Insert

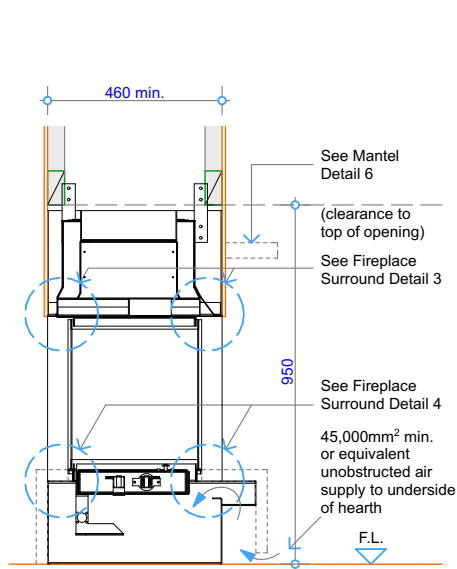

Cross Section - Fire Insert at Floor Level

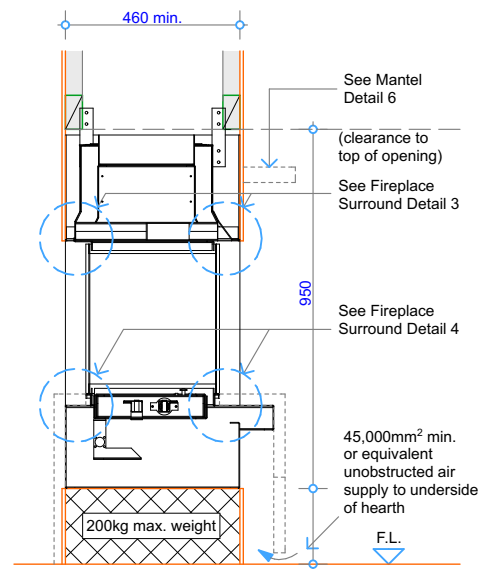

Cross Section - Fire Insert on Plinth

NOTE: Plinth height can vary to suit

COPYRIGHT ©
 THIS DRAWING IS THE PROPERTY
 OF **The Fire Dept.**

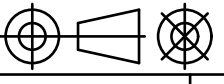
Client: THE FIRE DEPT.		
Product: GD3-1600-GLASS LEFT		
Title: CAVITY CLEARANCES		
Drawn: SR	Date: 27/03/2018	
Chkd: JW	Date: 27/03/2018	
Appd: JW	Date: 27/03/2018	
Scale:		on A4



Drawing No.	GD3-1600-902L	Sheet 02 of 08	Revision 4
-------------	----------------------	----------------	--

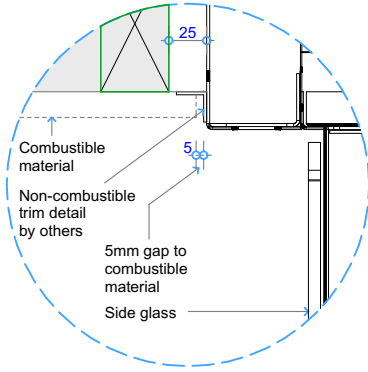

Detail 1 - Cross Section Fire Surround Opt. 1

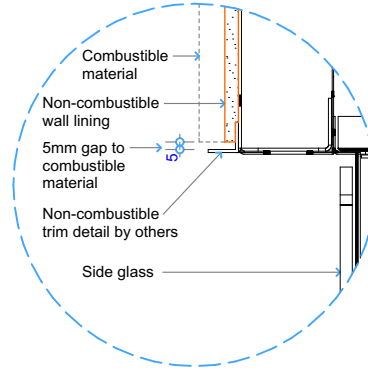

Detail 1 - Cross Section Fire Surround Opt. 2

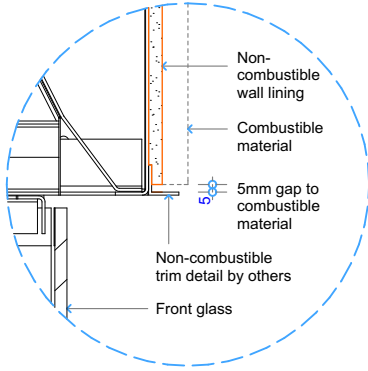

Detail 3 - Top of Fire to Combustible Materials

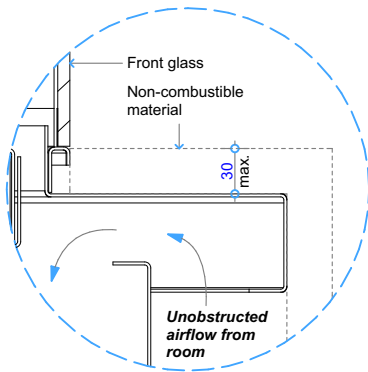

Detail 4 - Bottom of Fire to Floor Opt. 5

NOTE: 45,000mm² min. or equivalent unobstructed air supply to underside of hearth

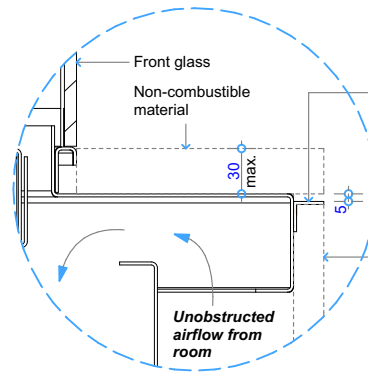

Detail 4 - Bottom of Fire to Floor Opt. 6

NOTE: 45,000mm² min. or equivalent unobstructed air supply to underside of hearth

COPYRIGHT ©
 THIS DRAWING IS THE PROPERTY
 OF **The Fire Dept.**

Client: THE FIRE DEPT.		
Product: GD3-1600-GLASS LEFT		
Title: SURROUND DETAILS		
Drawn: SR	Date: 27/03/2018	
Chkd: JW	Date: 27/03/2018	
Appd: JW	Date: 27/03/2018	
Scale:		on A4



Drawing No.	GD3-1600-903L	Sheet 03 of 08	Revision 4
-------------	----------------------	----------------	--

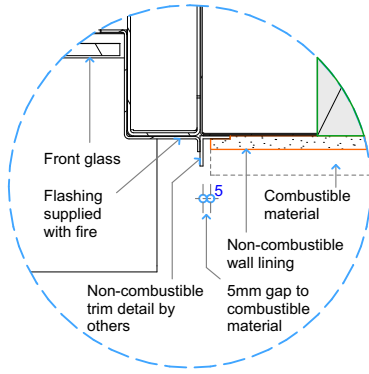

Detail 5 - Plan View Fire Surround Opt. 7

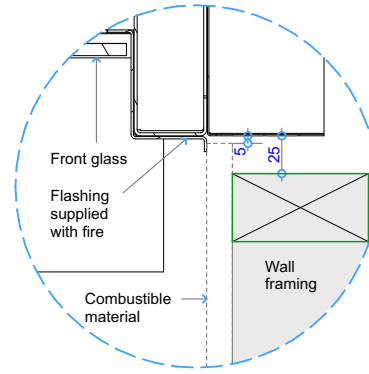

Detail 5 - Plan View Fire Surround Opt. 8

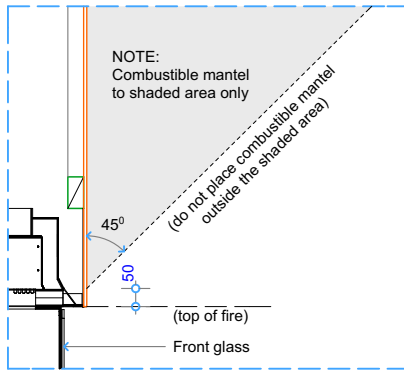

Detail 6 - Top of Fire to Combustible Mantel

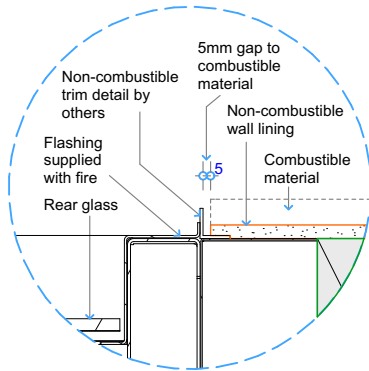

Detail 7 - Plan View Fire Surround Opt. 9

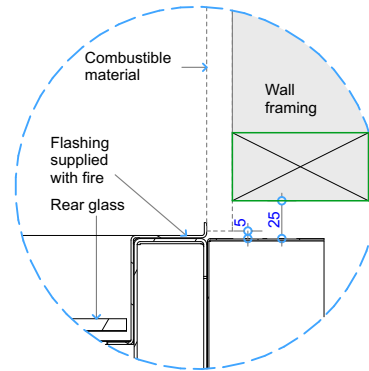

Detail 7 - Plan View Fire Surround Opt. 10

COPYRIGHT©
 THIS DRAWING IS THE PROPERTY
 OF **The Fire Dept.**

Client: THE FIRE DEPT.		
Product: GD3-1600-GLASS LEFT		
Title: SURROUND DETAILS		
Drawn: SR	Date: 27/03/2018	
Chkd: JW	Date: 27/03/2018	
Appd: JW	Date: 27/03/2018	
Scale:		on A4



Drawing No.	GD3-1600-904L	Sheet 04 of 08	Revision 4
-------------	----------------------	----------------	--

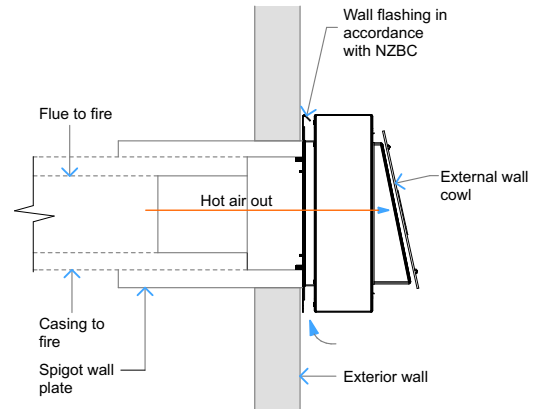
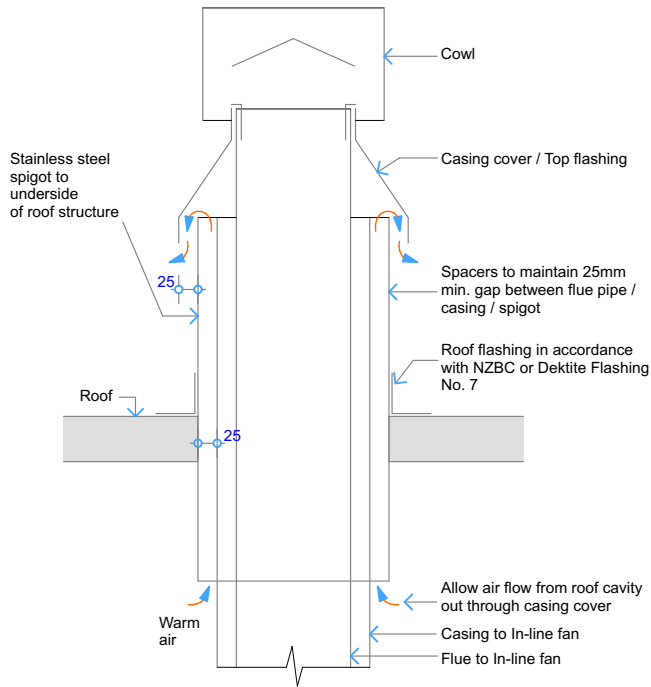

Detail - Air Ventilation through Casing cover/ Top flashing

Flue components:
 100mm dia. Flue
 150mm dia. Casing
 200mm dia. Spigot
 Deklite Flashing No. 7

NOTE:

Flue components must be installed to AS/NZS5601 requirements.
 All external penetration flashings must be installed in accordance with NZBC.
 Fire supplied with 3m of 5 core wire from fire to fan.
 Cavity airflow must be unobstructed from fire to flue termination.
 25mm clearance between flue and combustible materials.
 75mm clearance between flue and wiring / plastic water pipes.
 Horizontal flue run must fall 20mm for every 1000mm towards the fire.
 Each flue joint must be sealed with a heat proof sealer.
 Each flue joint must have a minimum of 4 x riverts.
 Flue to be adequately supported at 2.4m crs.

Detail - Air Ventilation through Wall

Flue components:
 100mm dia. Flue
 150mm dia. Casing
 200mm dia. Spigot

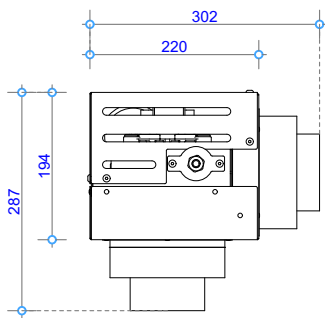

Detail - In-Line Fan

NOTE: Requires access hatch for maintenance

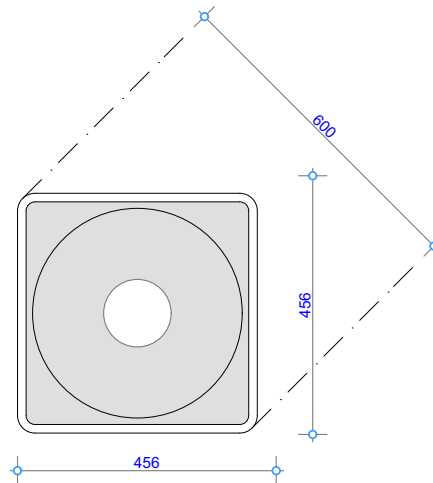

Deklite Flashing No. 7 - Plan View

COPYRIGHT © THIS DRAWING IS THE PROPERTY OF The Fire Dept.	Client: THE FIRE DEPT.			
	Product: GD3-1600-GLASS LEFT			
	Title: VERTICAL & HORIZONTAL FLUE EXIT DETAILS			
	Drawn: SR	Date: 27/03/2018		
	Chkd: JW	Date: 27/03/2018		
Appd: JW	Date: 27/03/2018			
Drawing No. GD3-1600-905L		Sheet 05 of 08	Revision 4	

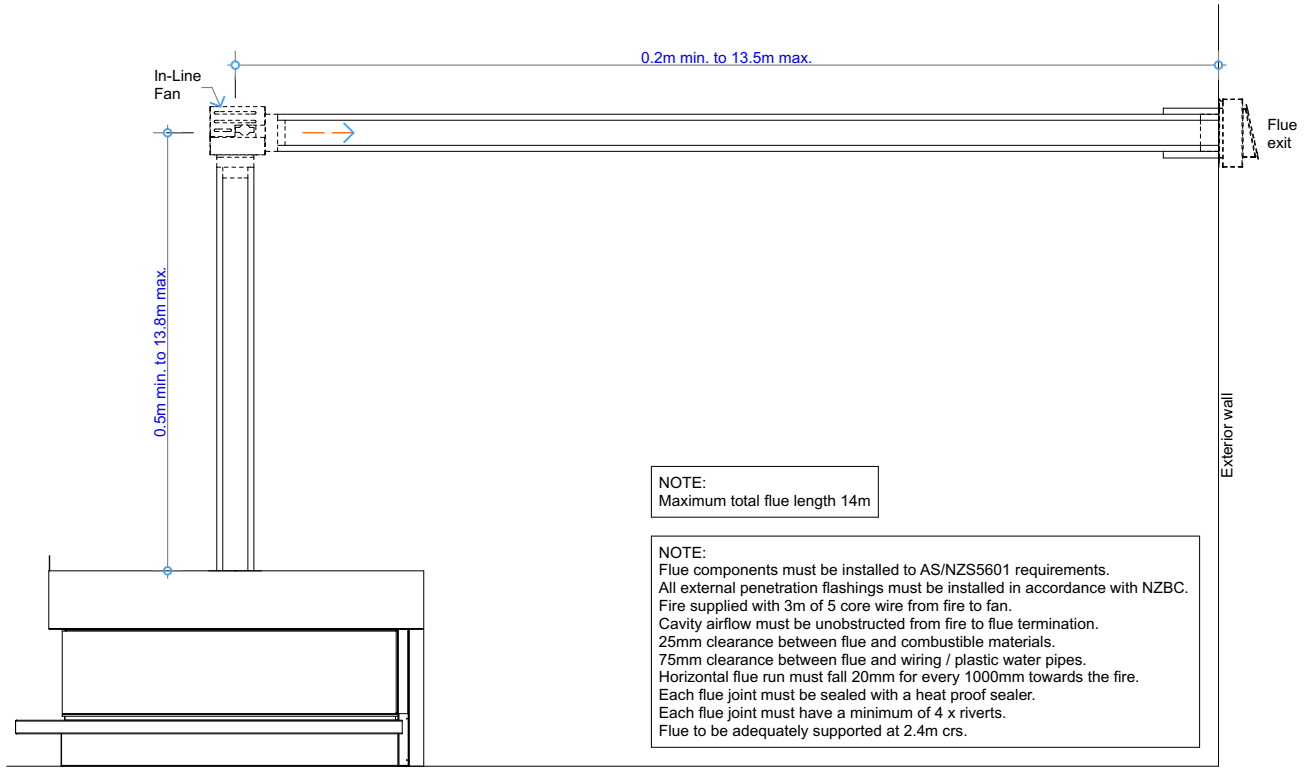

Horizontal Flue Combination GD3A

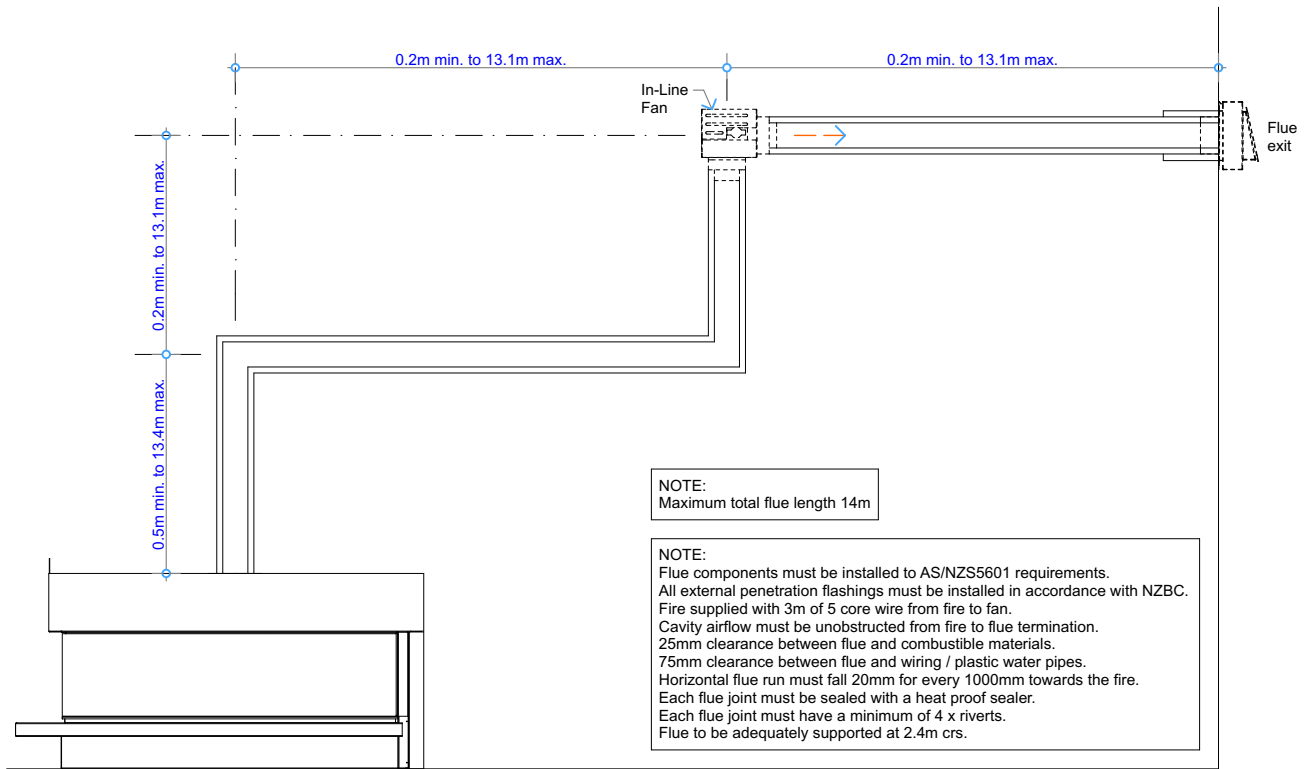

Horizontal Flue Combination GD3B

COPYRIGHT© THIS DRAWING IS THE PROPERTY OF The Fire Dept.	Client: THE FIRE DEPT.			
	Product: GD3-1600-GLASS LEFT			
	Title: HORIZONTAL FLUE COMBINATION OPTIONS			
	Drawn: SR	Date: 27/03/2018		
	Chkd: JW	Date: 27/03/2018		
Appd: JW	Date: 27/03/2018	Scale: on A4		
Drawing No.	GD3-1600-906L		Sheet 06 of 08	
			Revision 4	

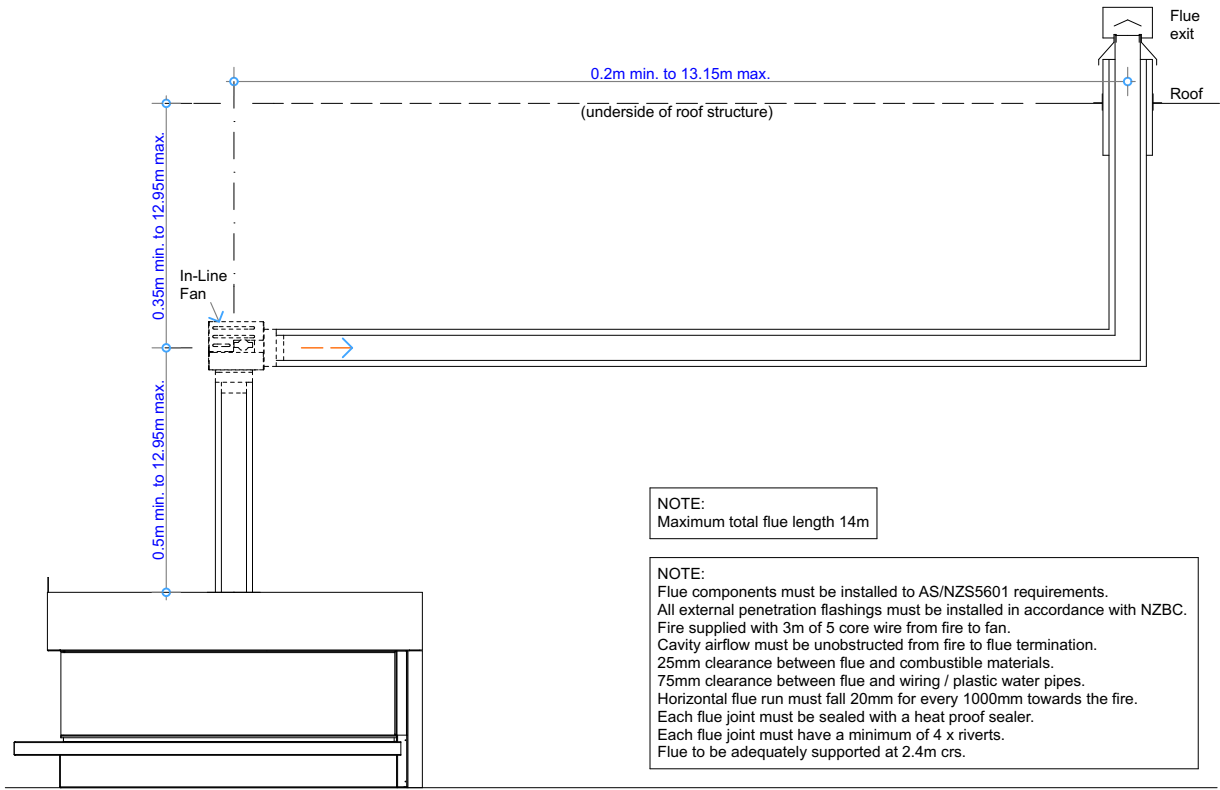

NOTE:
Maximum total flue length 14m

NOTE:
Flue components must be installed to AS/NZS5601 requirements.
All external penetration flashings must be installed in accordance with NZBC.
Fire supplied with 3m of 5 core wire from fire to fan.
Cavity airflow must be unobstructed from fire to flue termination.
25mm clearance between flue and combustible materials.
75mm clearance between flue and wiring / plastic water pipes.
Horizontal flue run must fall 20mm for every 1000mm towards the fire.
Each flue joint must be sealed with a heat proof sealer.
Each flue joint must have a minimum of 4 x rivets.
Flue to be adequately supported at 2.4m crs.

Vertical Flue Combination GD3C

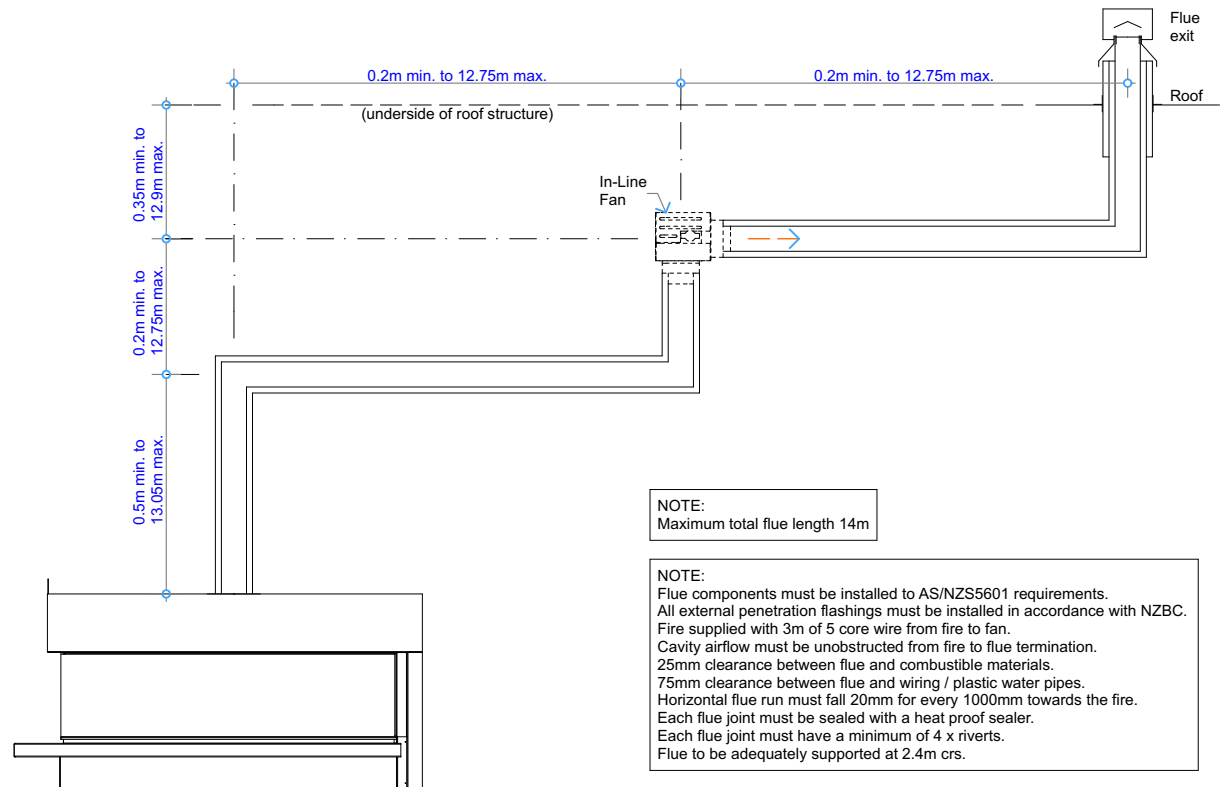

NOTE:
Maximum total flue length 14m

NOTE:
Flue components must be installed to AS/NZS5601 requirements.
All external penetration flashings must be installed in accordance with NZBC.
Fire supplied with 3m of 5 core wire from fire to fan.
Cavity airflow must be unobstructed from fire to flue termination.
25mm clearance between flue and combustible materials.
75mm clearance between flue and wiring / plastic water pipes.
Horizontal flue run must fall 20mm for every 1000mm towards the fire.
Each flue joint must be sealed with a heat proof sealer.
Each flue joint must have a minimum of 4 x rivets.
Flue to be adequately supported at 2.4m crs.

Vertical Flue Combination GD3D

COPYRIGHT ©
 THIS DRAWING IS THE PROPERTY
 OF The Fire Dept.

Client: THE FIRE DEPT.		
Product: GD3-1600-GLASS LEFT		
Title: VERTICAL FLUE COMBINATION OPTIONS		
Drawn: SR	Date: 27/03/2018	
Chkd: JW	Date: 27/03/2018	
Appd: JW	Date: 27/03/2018	
Scale:		on A4



Drawing No.	GD3-1600-907L	Sheet 07 of 08	Revision	4
-------------	---------------	----------------	----------	---

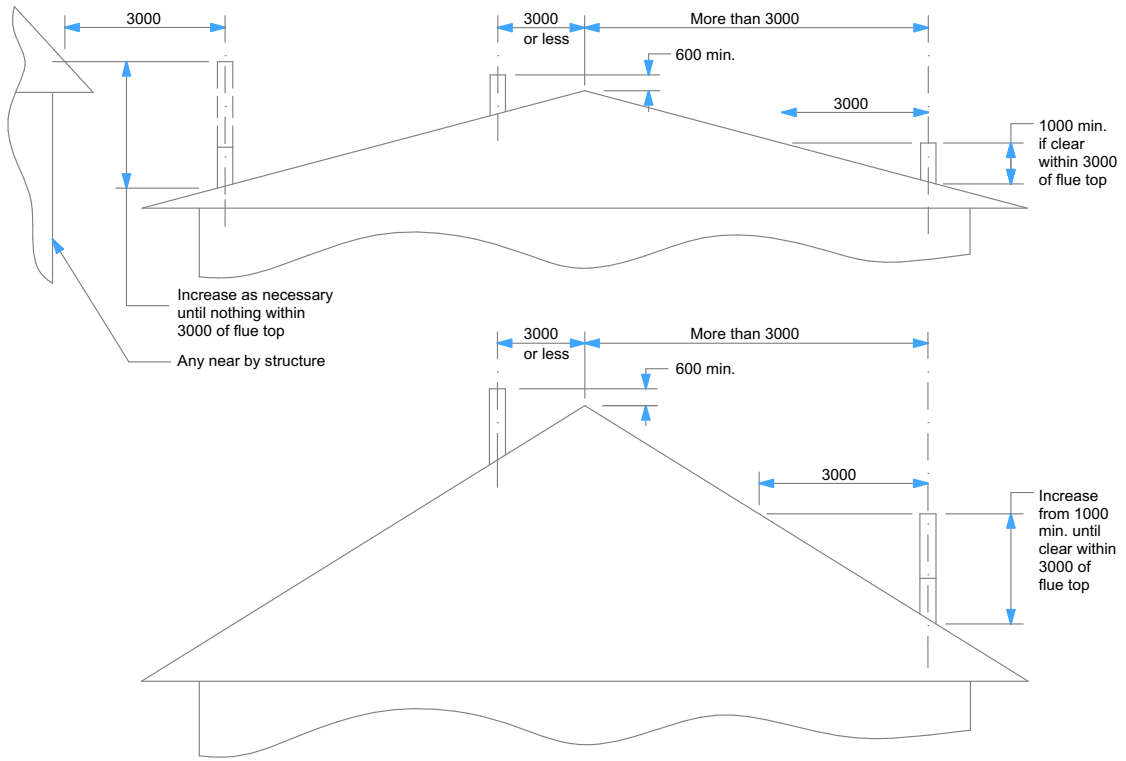

Minimum Height of Flue System Exit
Or as per AS/NZS 5601

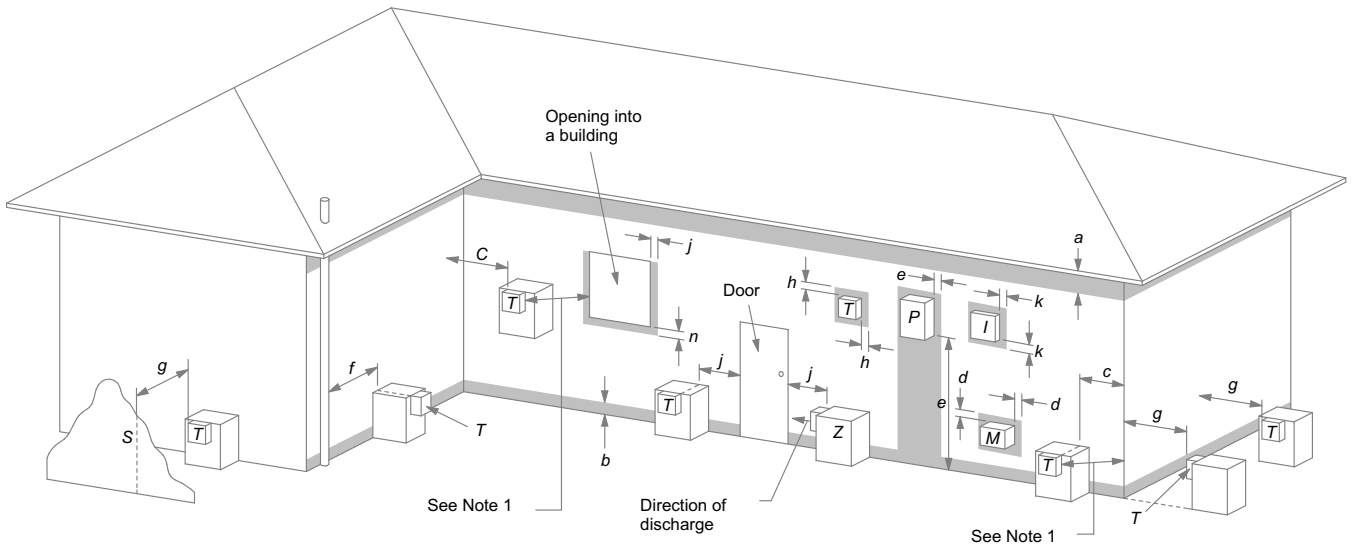

LEGEND:

- I = Mechanical air inlet
- M = Gas meter
- P = Electricity meter or fuse box
- S = Structure
- T = Flue terminal
- Z = Fan-assisted appliance only

- a = 200
- b = 300
- c = 300
- d = 1000
- e = 500
- f = 75
- g = 500
- h = 300
- j = 300 (at window) & 1500 (fan-assisted appliance by the door)
- k = 1000
- n = 500

NOTES:

- 1 Where dimensions c, j or k cannot be achieved an equivalent horizontal distance measured diagonally from the nearest discharge point of the terminal to the opening may be deemed by the Technical Regulator to comply.

Shading indicates prohibited area for flue terminals

Location of Flue Terminals of Balanced Flue, Room-Sealed, Fan-Assisted or Outdoor Appliances

NOTE: To be read in conjunction with AS/NZS 5601.1:2013

COPYRIGHT ©
 THIS DRAWING IS THE PROPERTY
 OF The Fire Dept.

Client: THE FIRE DEPT.		
Product: GD3-1600-GLASS LEFT		
Title: FLUE EXIT CLEARANCES		
Drawn: SR	Date: 27/03/2018	
Chkd: JW	Date: 27/03/2018	
Appd: JW	Date: 27/03/2018	
Scale:		on A4



Drawing No.	GD3-1600-908L	Sheet 08 of 08	Revision 4
-------------	----------------------	----------------	--