

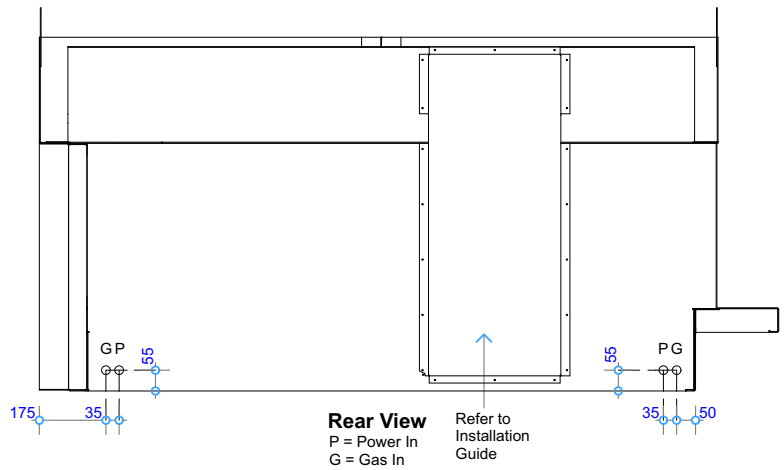

## **GD4 - 1600 Glass Left**

### **Specifications**

Information in this specification may be subject to change without notice. Please ensure you have the current version before beginning installation.

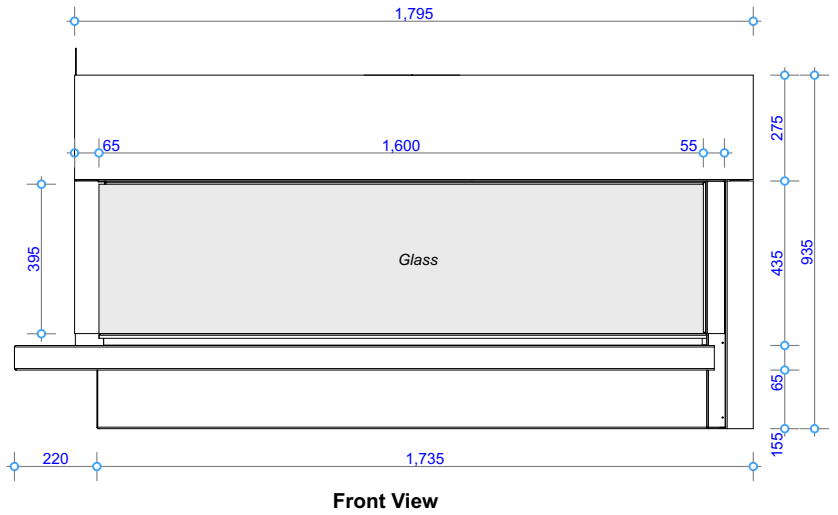
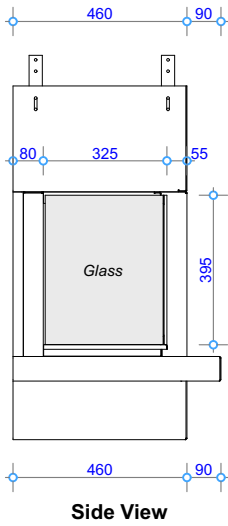
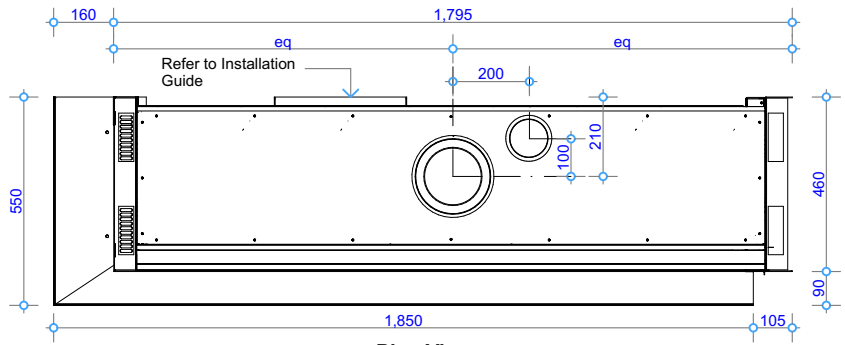

TOLERANCE = +/- 3mm

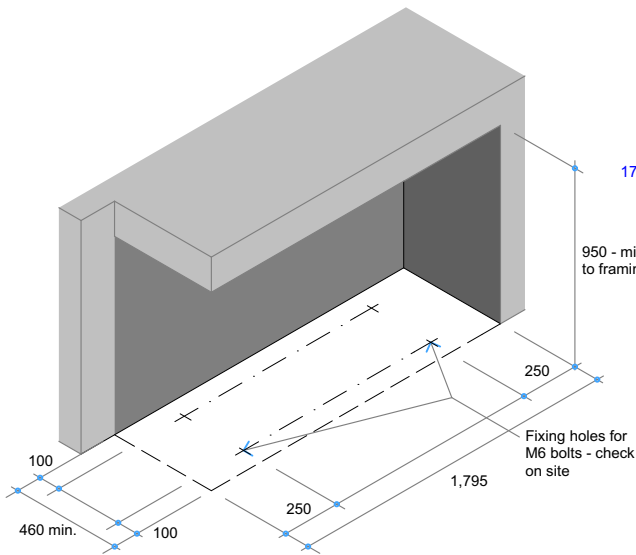

**Fire Installation - Trim Sizes**

NOTE: Confirm fixing holes on site prior to drilling

COPYRIGHT ©  
THIS DRAWING IS THE PROPERTY  
OF The Fire Dept.

Client: THE FIRE DEPT.		
Product: GD4-1600-GLASS LEFT		
Title: FIREBOX DIMENSIONS		
Drawn: SR	Date: 08/05/2018	
Chkd: JW	Date: 08/05/2018	
Appd: JW	Date: 08/05/2018	
Scale:		on A4



Drawing No.	<b>GD4-1600-901L</b>	Sheet 01 of 08	Revision	5
-------------	----------------------	----------------	----------	---

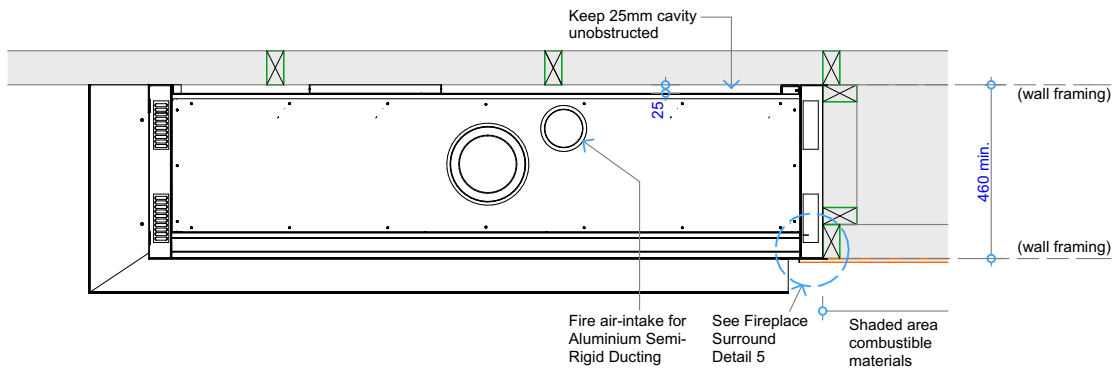

**Plan View - Fire Insert**

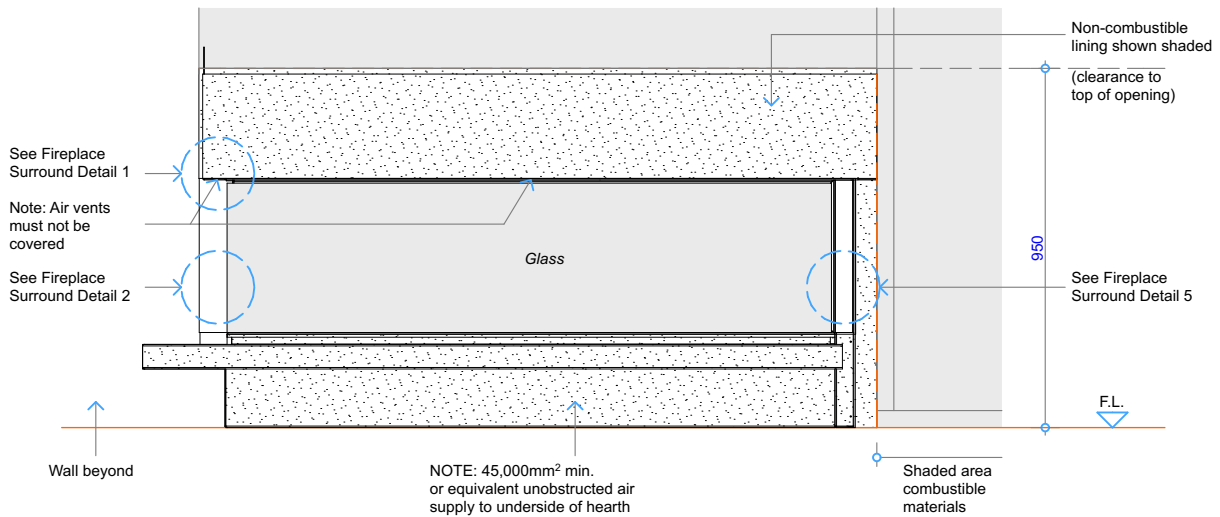

**Front View - Fire Insert**

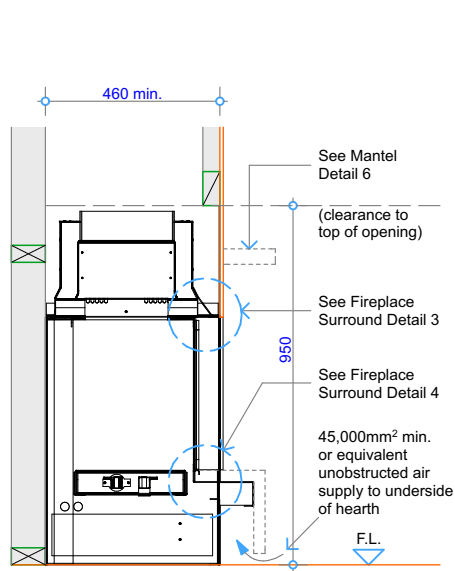

**Cross Section - Fire Insert at Floor Level**

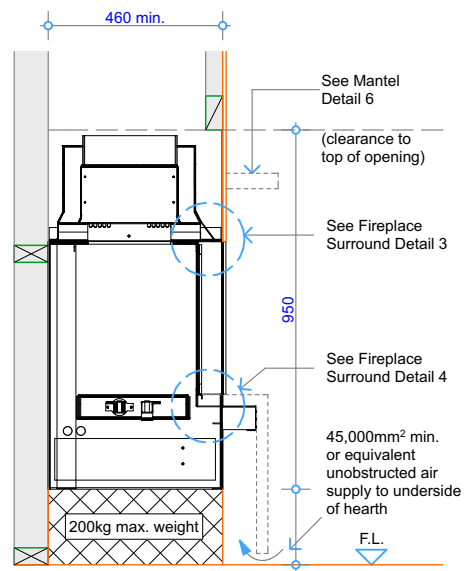

**Cross Section - Fire Insert on Raised Plinth**

NOTE: Plinth height can vary to suit

COPYRIGHT ©  
 THIS DRAWING IS THE PROPERTY  
 OF **The Fire Dept.**

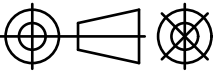
Client: THE FIRE DEPT.		
Product: GD4-1600-GLASS LEFT		
Title: CAVITY CLEARANCES		
Drawn: SR	Date: 08/05/2018	
Chkd: JW	Date: 08/05/2018	
Appd: JW	Date: 08/05/2018	
Scale:		on A4

**THE FIRE DEPT.**

Drawing No. **GD4-1600-902L**

Sheet 02 of 08

Revision **5**

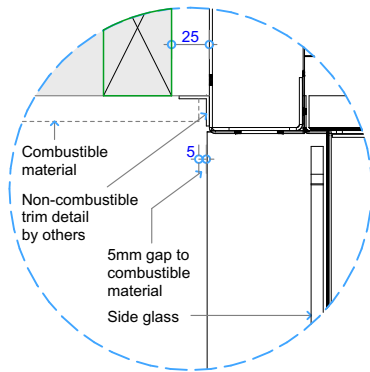

**Detail 1 - Cross Section Fire Surround Opt. 1**

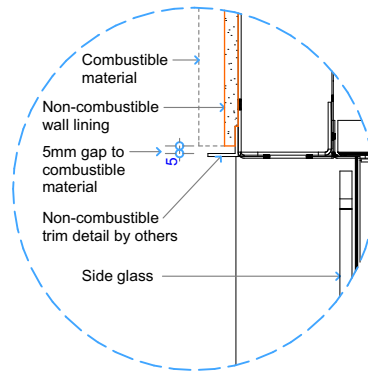

**Detail 1 - Cross Section Fire Surround Opt. 2**

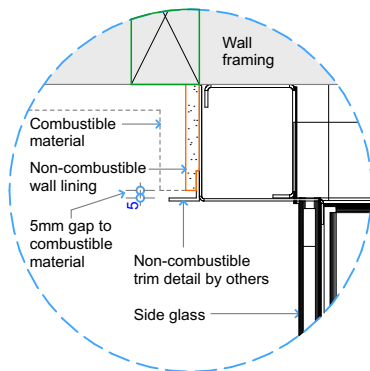

**Detail 2 - Plan View Fire Surround Opt. 3**

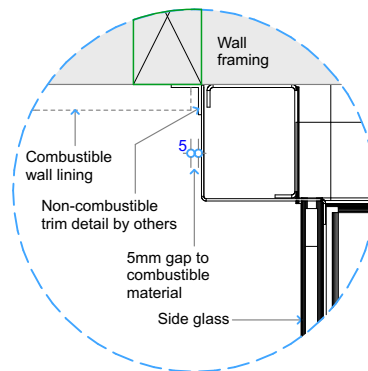

**Detail 2 - Plan View Fire Surround Opt. 4**

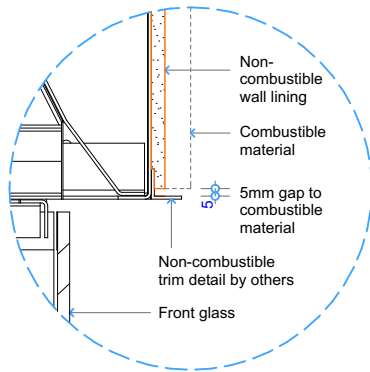

**Detail 3 - Top of Fire to Combustible Materials**

COPYRIGHT©  
 THIS DRAWING IS THE PROPERTY  
 OF **The Fire Dept.**

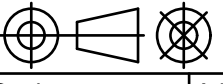
Client: THE FIRE DEPT.		
Product: GD4-1600-GLASS LEFT		
Title: SURROUND DETAILS		
Drawn: SR	Date: 08/05/2018	
Chkd: JW	Date: 08/05/2018	
Appd: JW	Date: 08/05/2018	
Scale:		on A4



Drawing No.	<b>GD4-1600-903L</b>	Sheet 03 of 08	Revision <span style="border: 1px solid black; padding: 2px;">5</span>
-------------	----------------------	----------------	--

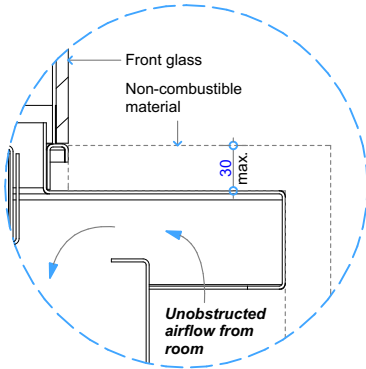

**Detail 4 - Bottom of Fire to Floor Opt. 5**  
 NOTE: 45,000mm<sup>2</sup> min. or equivalent unobstructed air supply to underside of hearth

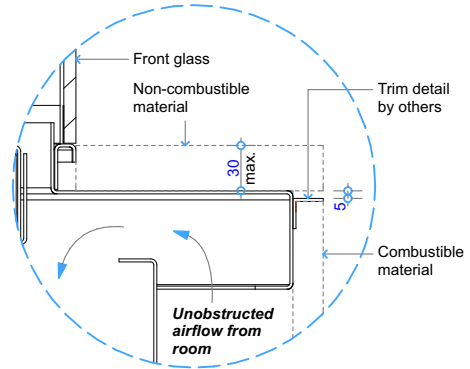

**Detail 4 - Bottom of Fire to Floor Opt. 6**  
 NOTE: 45,000mm<sup>2</sup> min. or equivalent unobstructed air supply to underside of hearth

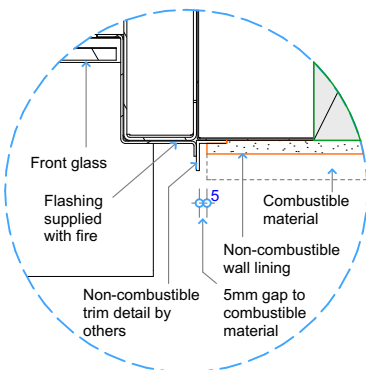

**Detail 5 - Plan View Fire Surround Opt. 7**

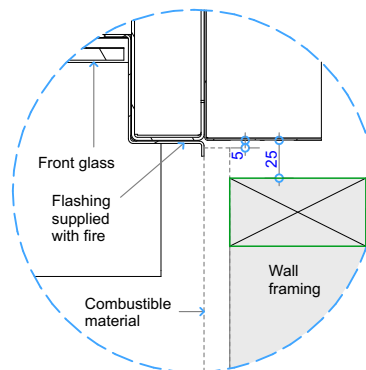

**Detail 5 - Plan View Fire Surround Opt. 8**

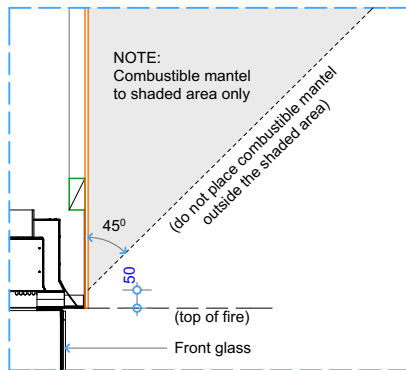

**Detail 6 - Top of Fire to Combustible Mantel**

COPYRIGHT©  
 THIS DRAWING IS THE PROPERTY  
 OF The Fire Dept.

Client: THE FIRE DEPT.		
Product: GD4-1600-GLASS LEFT		
Title: SURROUND DETAILS		
Drawn: SR	Date: 08/05/2018	
Chkd: JW	Date: 08/05/2018	
Appd: JW	Date: 08/05/2018	
Scale: on A4		

Drawing No.	<b>GD4-1600-904L</b>	Sheet 04 of 08	Revision <span style="border: 1px solid black; padding: 2px;">5</span>
-------------	----------------------	----------------	--

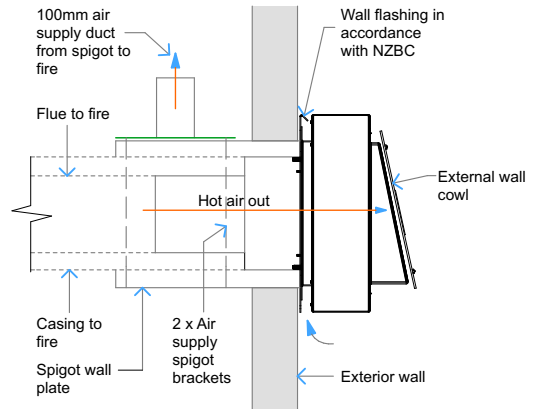
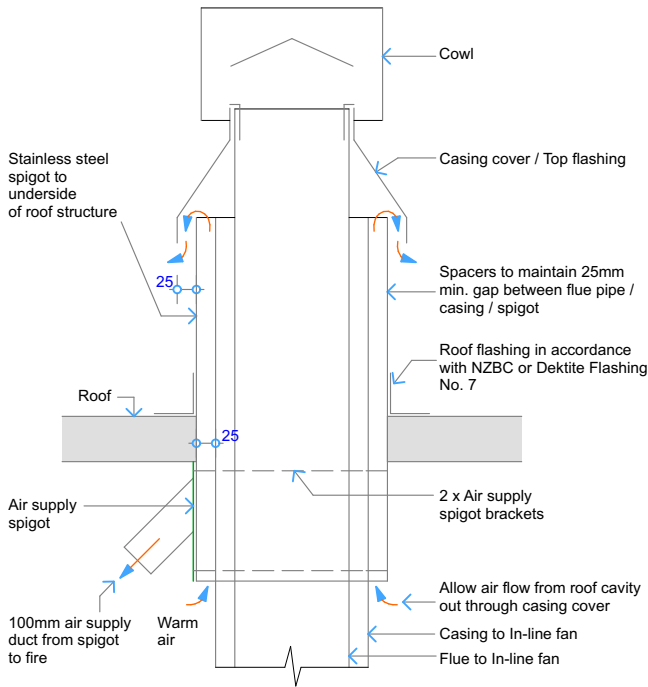

**Detail - Air Ventilation through Casing cover/ Top flashing**

Flue components:  
 100mm dia. Flue  
 150mm dia. Casing  
 200mm dia. Spigot  
 Deklite Flashing No. 7

**NOTE:**  
 Flue components must be installed to AS/NZS5601 requirements.  
 All external penetration flashings must be installed in accordance with NZBC.  
 Fire supplied with 3m of 5 core wire from fire to fan.  
 Cavity airflow must be unobstructed from fire to flue termination.  
 25mm clearance between flue and combustible materials.  
 75mm clearance between flue and wiring / plastic water pipes.  
 Horizontal flue run must fall 20mm for every 1000mm towards the fire.  
 Each flue joint must be sealed with a heat proof sealer.  
 Each flue joint must have a minimum of 4 x rivets.  
 Flue to be adequately supported at 2.4m crs.  
 Fix Aluminium Semi-Rigid Duct with 4 x rivets and sufficient duct tape to fire, spigot, and at each joint.

**Detail - Air Ventilation through Wall**

Flue components:  
 100mm dia. Flue  
 150mm dia. Casing  
 200mm dia. Spigot

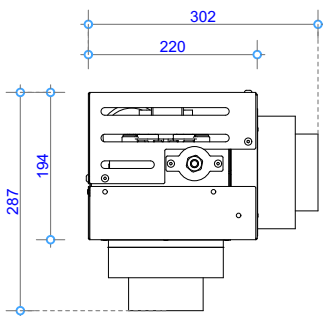

**Detail - In-Line Fan**

NOTE: Requires access hatch for maintenance

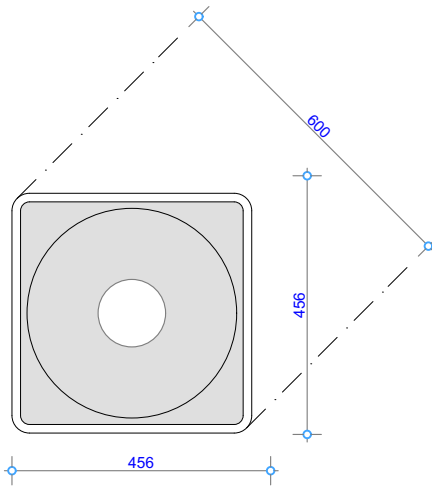

**Deklite Flashing No. 7 - Plan View**

COPYRIGHT© THIS DRAWING IS THE PROPERTY OF The Fire Dept.	Client: THE FIRE DEPT.			
	Product: GD4-1600-GLASS LEFT			
	Title: VERTICAL & HORIZONTAL FLUE EXIT DETAILS			
	Drawn: SR	Date: 08/05/2018		
	Chkd: JW	Date: 08/05/2018		
Appd: JW	Date: 08/05/2018	Scale: on A4		
Drawing No.	GD4-1600-905L		Sheet 05 of 08	Revision 5

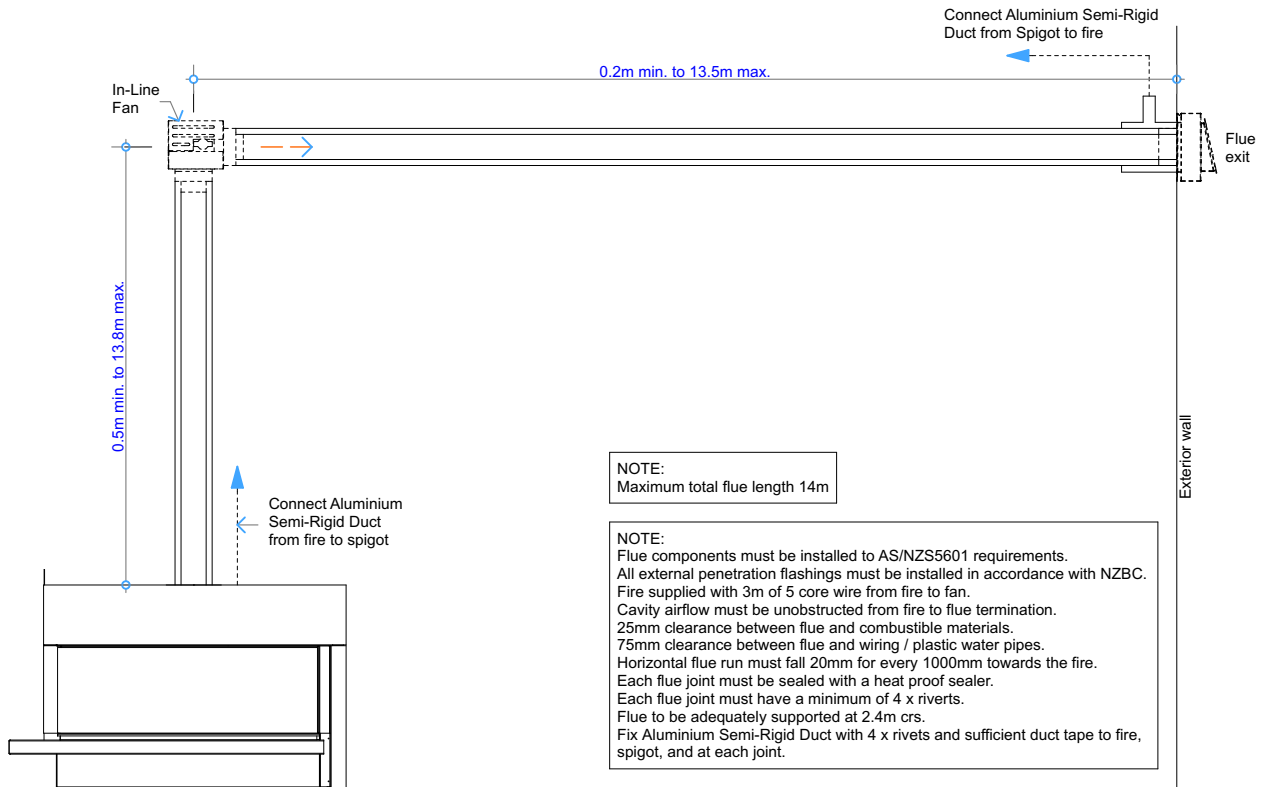

Horizontal Flue Combination GD4A

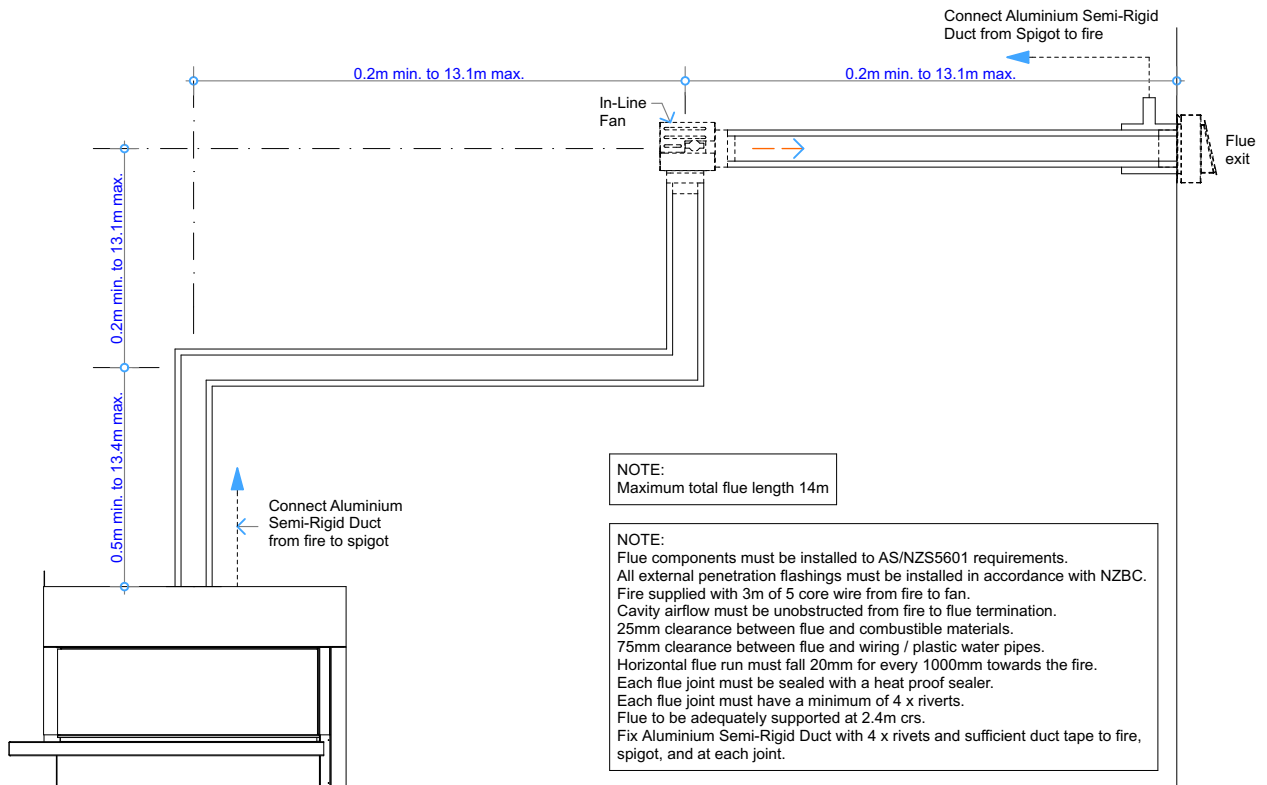

Horizontal Flue Combination GD4B

COPYRIGHT © THIS DRAWING IS THE PROPERTY OF The Fire Dept.	Client: THE FIRE DEPT.			
	Product: GD4-1600-GLASS LEFT			
	Title: HORIZONTAL FLUE COMBINATION OPTIONS			
	Drawn: SR	Date: 08/05/2018		
	Chkd: JW	Date: 08/05/2018		
Appd: JW	Date: 08/05/2018	Scale: on A4		
Drawing No.	GD4-1600-906L		Sheet 06 of 08	Revision 5

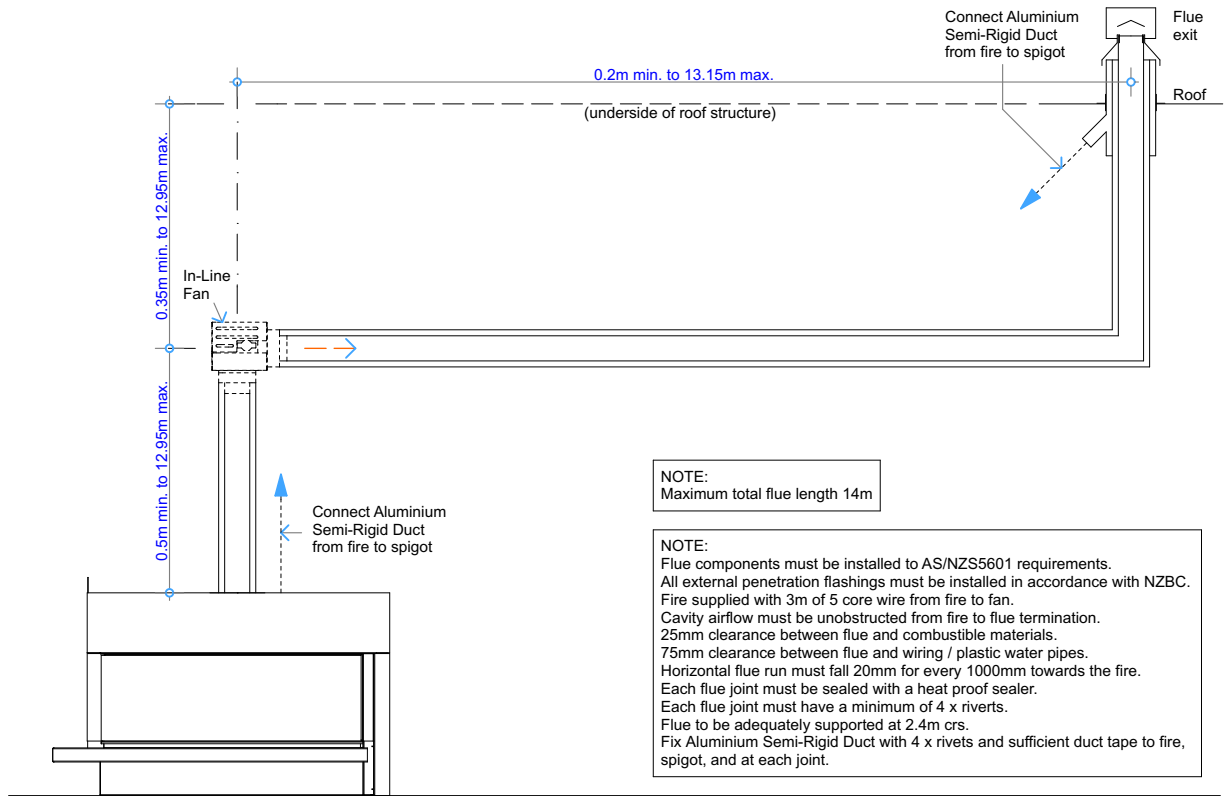

Vertical Flue Combination GD4C

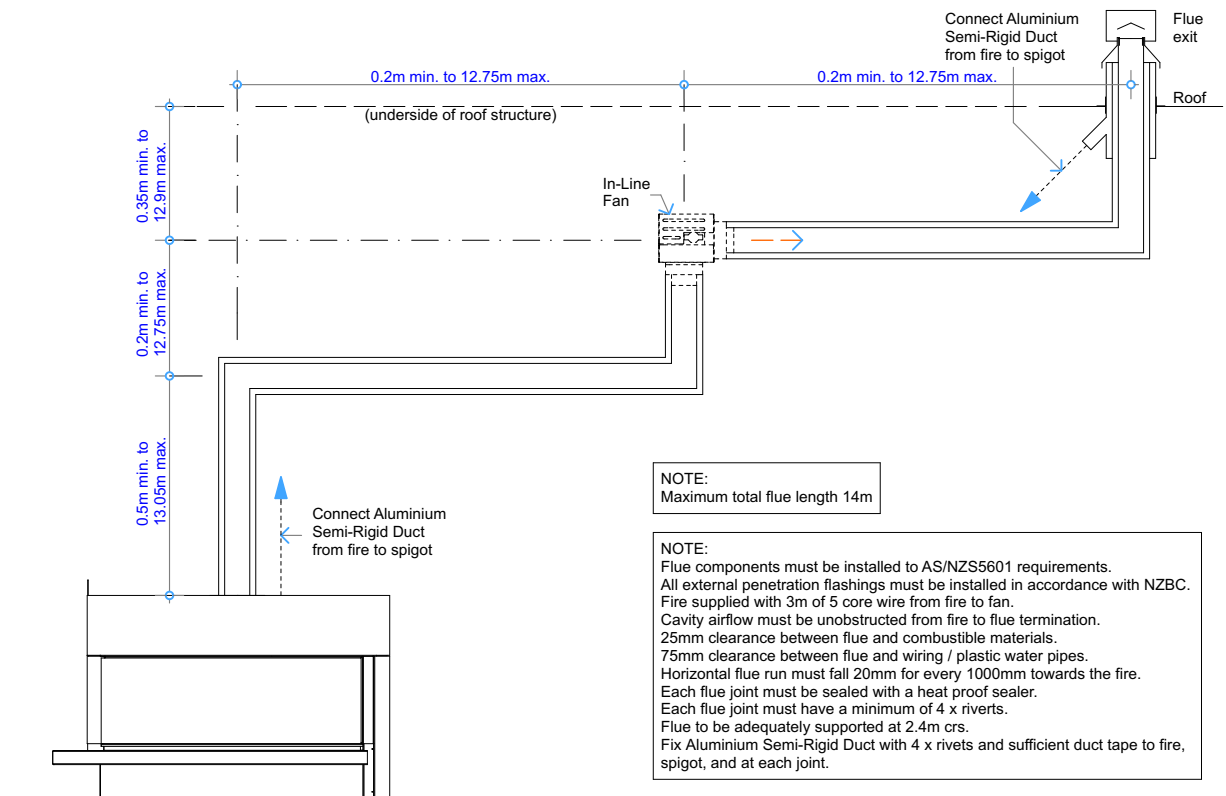

Vertical Flue Combination GD4D

COPYRIGHT©  
THIS DRAWING IS THE PROPERTY  
OF The Fire Dept.

Client: THE FIRE DEPT.

Product: GD4-1600-GLASS LEFT

Title: VERTICAL FLUE COMBINATION OPTIONS

Drawn: SR

Date: 08/05/2018

Chkd: JW

Date: 08/05/2018

Appd: JW

Date: 08/05/2018

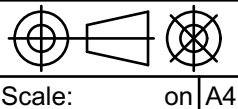

Scale: on A4

THE  
**FIRE  
DEPT.**

Drawing No. **GD4-1600-907L**

Sheet 07 of 08

Revision **5**



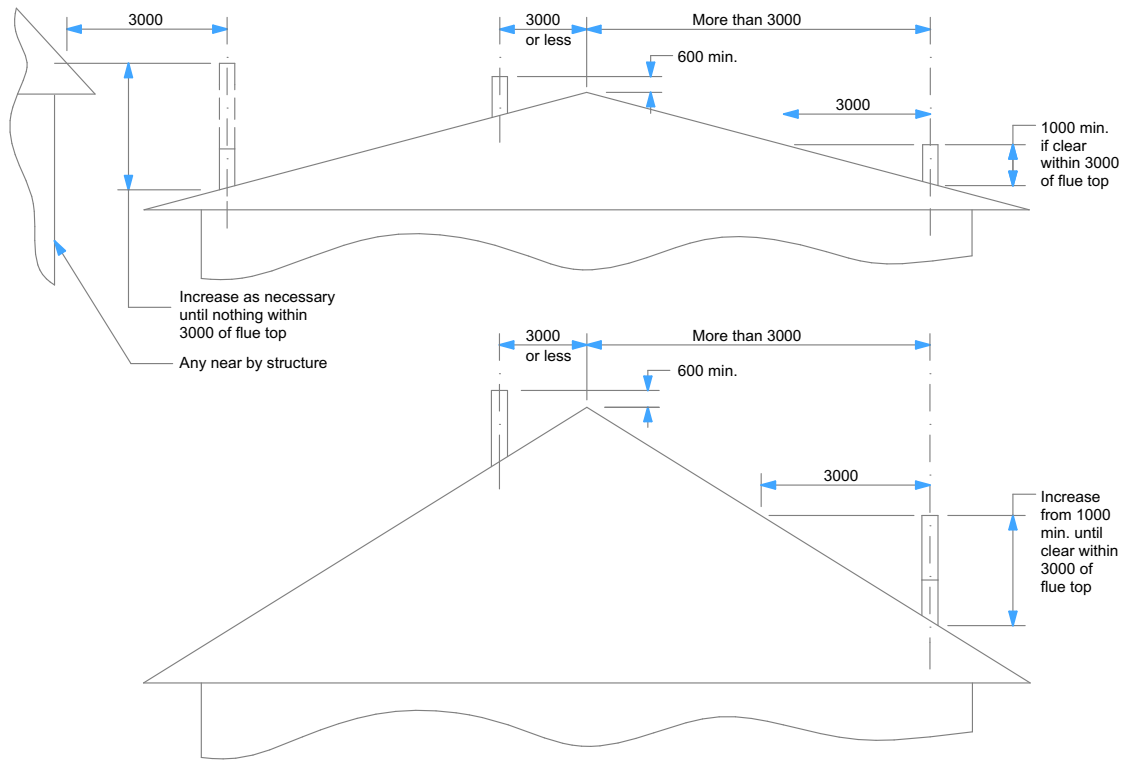

**Minimum Height of Flue System Exit**  
Or as per AS/NZS 5601

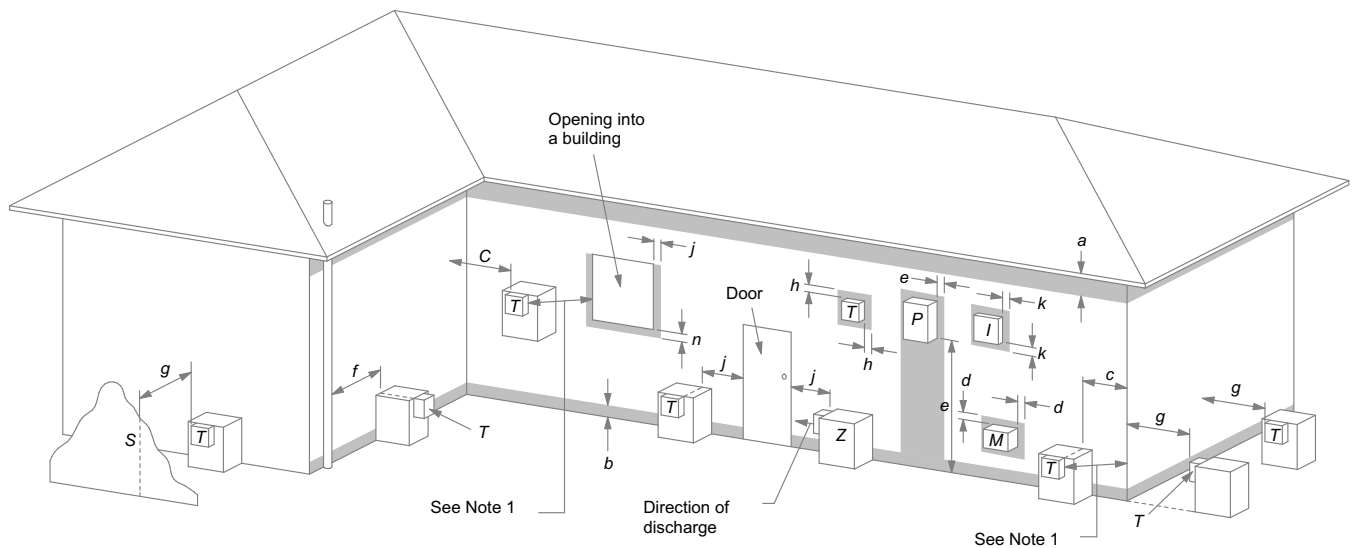

**LEGEND:**

- I = Mechanical air inlet
- M = Gas meter
- P = Electricity meter or fuse box
- S = Structure
- T = Flue terminal
- Z = Fan-assisted appliance only

- a = 200
- b = 300
- c = 300
- d = 1000
- e = 500
- f = 75
- g = 500
- h = 300
- j = 300 (at window) & 1500 (fan-assisted appliance by the door)
- k = 1000
- n = 500

**NOTES:**

- 1 Where dimensions c, j or k cannot be achieved an equivalent horizontal distance measured diagonally from the nearest discharge point of the terminal to the opening may be deemed by the *Technical Regulator* to comply.

Shading indicates prohibited area for flue terminals

**Location of Flue Terminals of Balanced Flue, Room-Sealed, Fan-Assisted or Outdoor Appliances**

**NOTE:** To be read in conjunction with AS/NZS 5601.1:2013

COPYRIGHT ©  
 THIS DRAWING IS THE PROPERTY  
 OF The Fire Dept.

Client: THE FIRE DEPT.

Product: GD4-1600-GLASS LEFT

Title: FLUE EXIT CLEARANCES

Drawn: SR

Date: 08/05/2018

Chkd: JW

Date: 08/05/2018

Appd: JW

Date: 08/05/2018

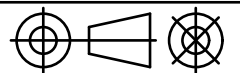

Scale: on A4



Drawing No. **GD4-1600-908L**

Sheet 08 of 08

Revision **5**