

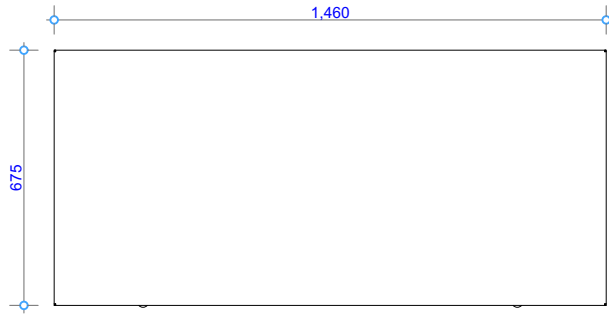

GD61 - 1200

Specifications

Information in this specification may be subject to change without notice. Please ensure you have the current version before beginning installation.



Plan View

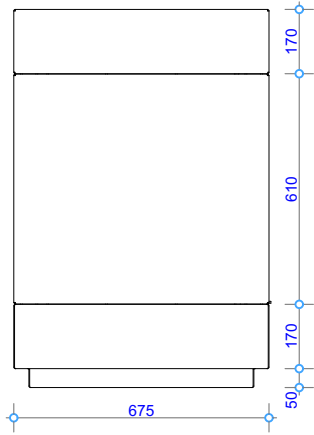

Side View

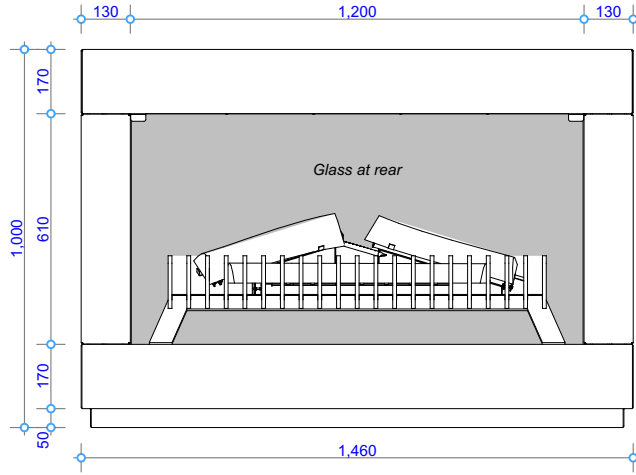

Front View

TOLERANCE = +/- 3mm

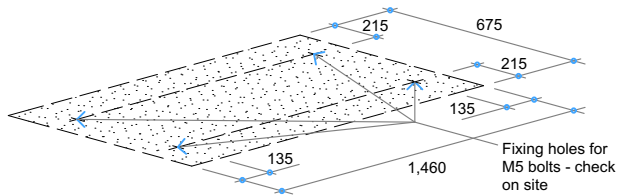

Fire Installation

NOTE: Confirm fixing holes on site prior to drilling

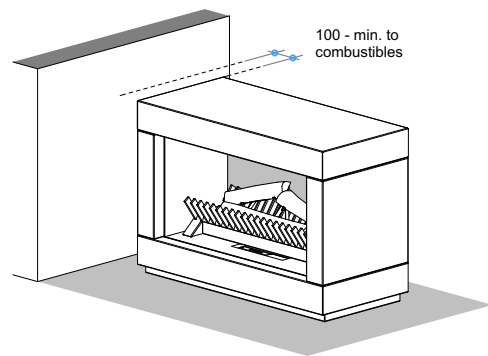

Fire Installation - Clearance to Combustibles

COPYRIGHT©
THIS DRAWING IS THE PROPERTY
OF The Fire Dept.

Client: THE FIRE DEPT.		
Product: GD61-1200		
Title: FIREBOX DIMENSIONS		
Drawn: SR	Date: 08/12/2017	
Chkd: JW	Date: 08/12/2017	
Appd: JW	Date: 08/12/2017	
Scale:		on A4

THE FIRE DEPT.

Drawing No.	GD61-1200-901	Sheet 01 of 02	Revision 0
-------------	----------------------	----------------	--

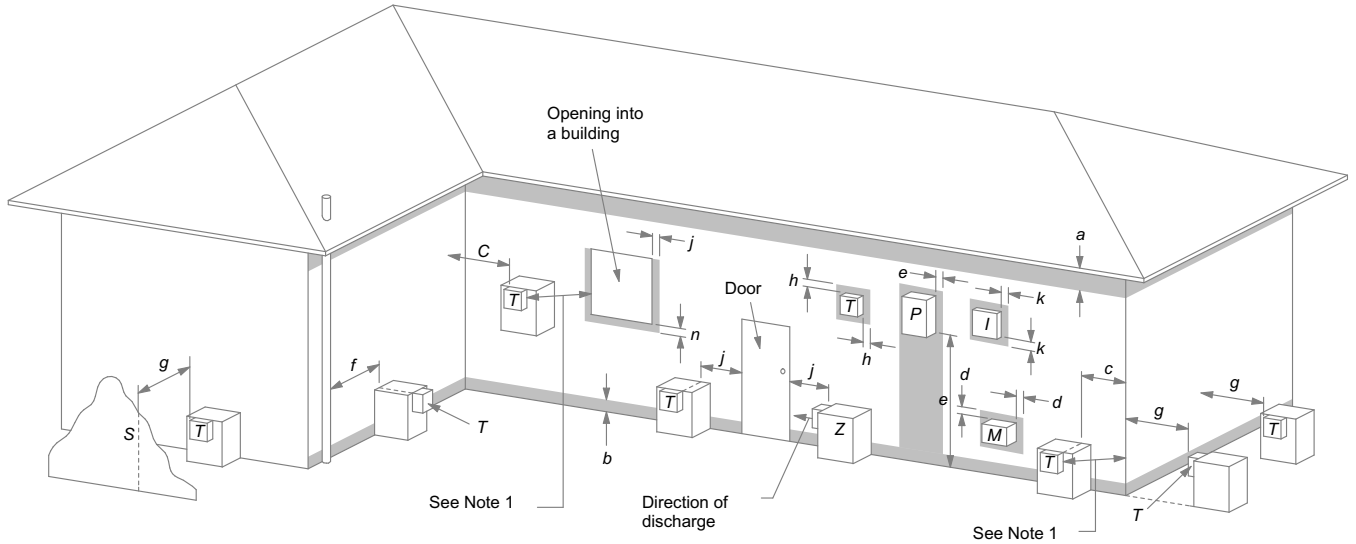

LEGEND:

- I = Mechanical air inlet
- M = Gas meter
- P = Electricity meter or fuse box
- S = Structure
- T = Flue terminal
- Z = Fan-assisted appliance only

- a = 200
- b = 300
- c = 300
- d = 1000
- e = 500
- f = 75
- g = 500
- h = 300
- j = 300 (at window) & 1500 (fan-assisted appliance by the door)
- k = 1000
- n = 500

NOTES:

- 1 Where dimensions *c*, *j* or *k* cannot be achieved an equivalent horizontal distance measured diagonally from the nearest discharge point of the terminal to the opening may be deemed by the *Technical Regulator* to comply.

Shading indicates prohibited area for flue terminals

Location of Flue Terminals of Balanced Flue, Room-Sealed, Fan-Assisted or Outdoor Appliances

NOTE: To be read in conjunction with AS/NZS 5601.1:2013

COPYRIGHT ©
 THIS DRAWING IS THE PROPERTY
 OF The Fire Dept.

Client: THE FIRE DEPT.

Product: GD61-1200

Title: FLUE EXIT CLEARANCES

Drawn: SR

Date: 08/12/2017

Chkd: JW

Date: 08/12/2017

Appd: JW

Date: 08/12/2017

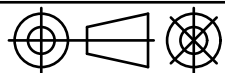

Scale: on A4



Drawing No. **GD61-1200-902**

Sheet 02 of 02

Revision

0