

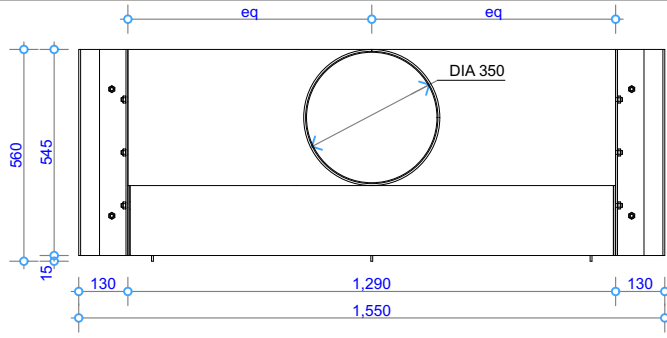

WD1 – 1300 Open Front, Left & Right

Specifications

Information in this specification may be subject to change without notice. Please ensure you have the current version before beginning installation.



Plan View

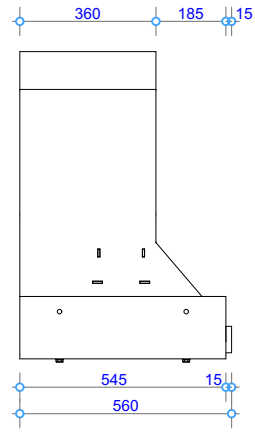

Side View

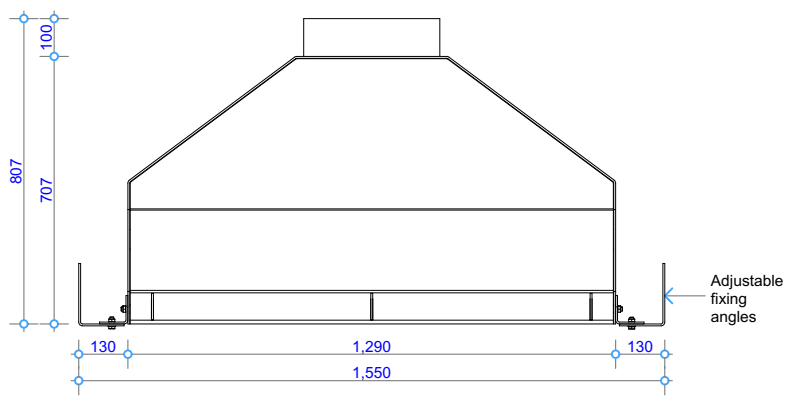

Front View

TOLERANCE = +/- 3mm

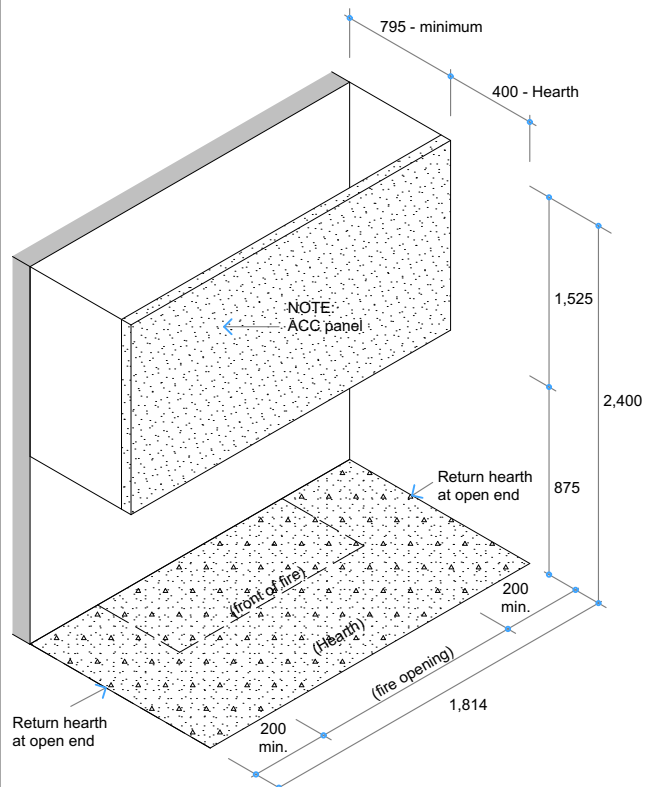

Fire Installation Requirements & Hearth Size - Timber Cavity

NOTE: Hearth to extend minimum of 200mm both sides of fire opening, and 400mm from front of fire opening

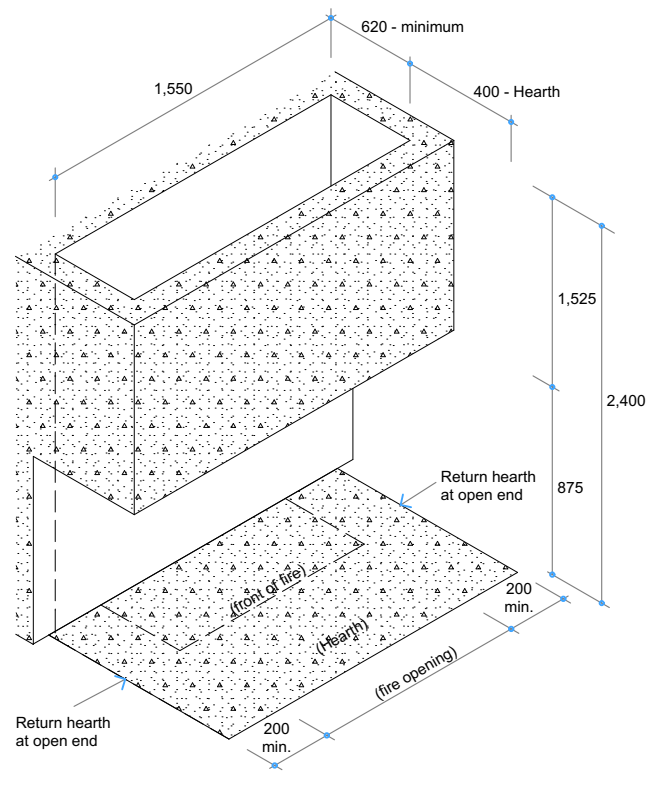

Fire Installation Requirements & Hearth Size - Concrete Cavity

NOTE: Hearth to extend minimum of 200mm both sides of fire opening, and 400mm from front of fire opening

COPYRIGHT © THIS DRAWING IS THE PROPERTY OF The Fire Dept.

Client: THE FIRE DEPT.		
Product: WD10U-1300		
Title: FIRE DIMENSIONS		
Drawn: SR	Date: 31/05/2018	
Chkd: JW	Date: 31/05/2018	
Appd: JW	Date: 31/05/2018	
Scale:		on A4



Drawing No.	WD10U-1300-901	Sheet 01 of 14	Revision 4
-------------	----------------	----------------	------------

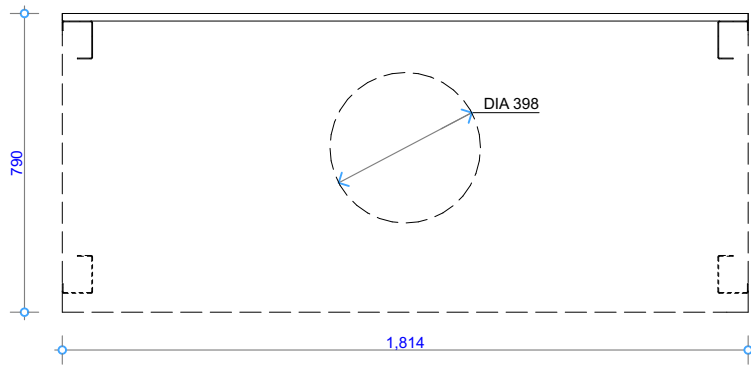

Plan View

Information in this specification may be subject to change without notice. Please ensure you have the current version before beginning installation.

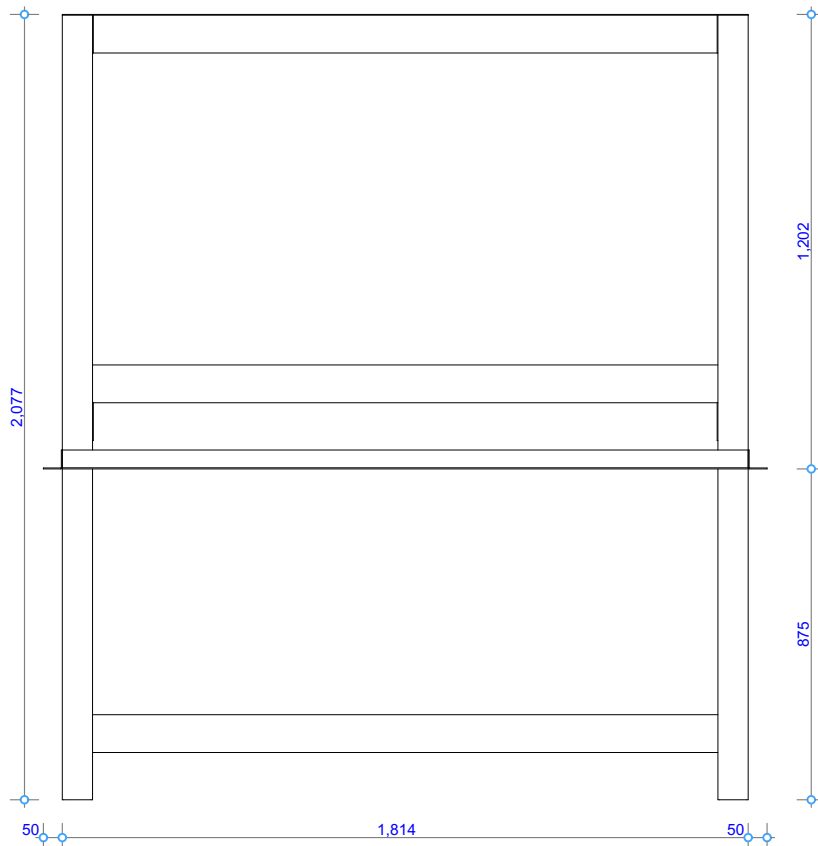

Front View

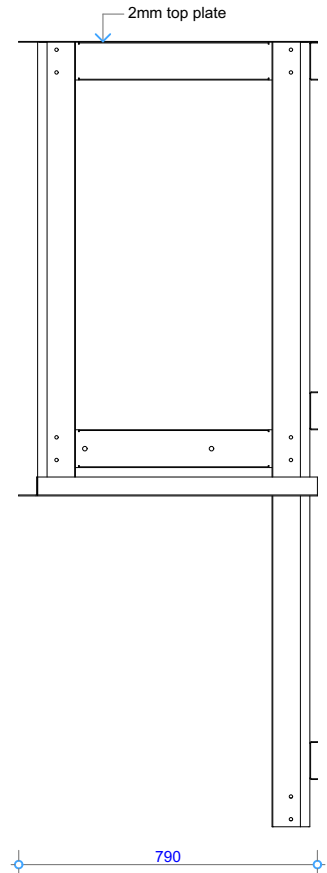

Side View

COPYRIGHT©
THIS DRAWING IS THE PROPERTY
OF The Fire Dept.

Client: THE FIRE DEPT.

Product: WD1OU-1300

Title: STEEL SUPPORT FRAME DIMENSIONS

Drawn: SR

Date: 31/05/2018

Chkd: JW

Date: 31/05/2018

Appd: JW

Date: 31/05/2018

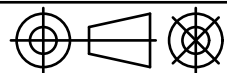

Scale: on A4

THE FIRE DEPT.

Drawing No. **WD1OU-1300-902**

Sheet 02 of 14

Revision

4

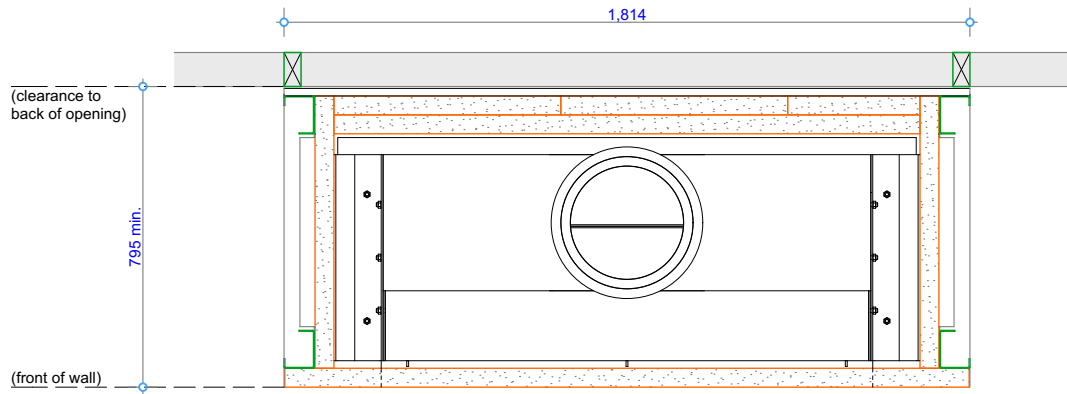

Plan View - Fire Insert (above fire gather)

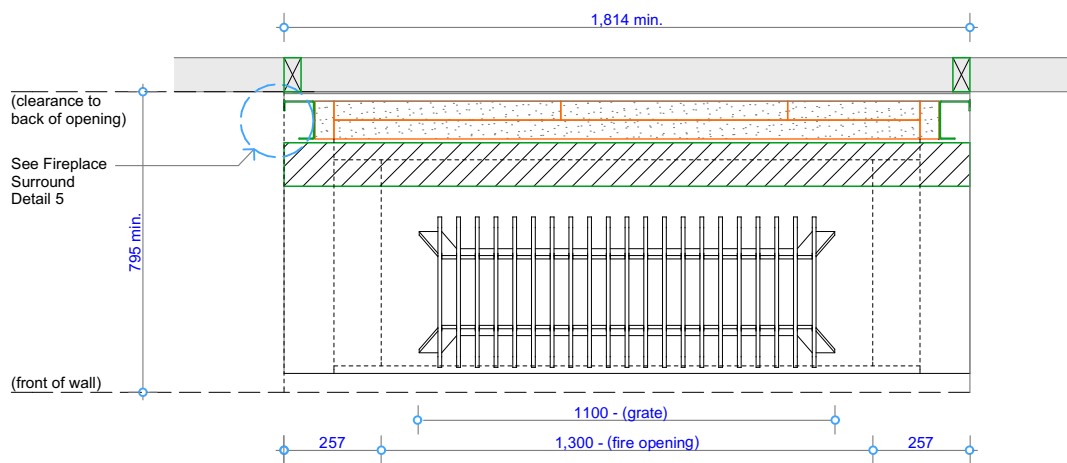

Plan View - Fire Insert (below fire gather)

COPYRIGHT©
 THIS DRAWING IS THE PROPERTY
 OF **The Fire Dept.**

Client: THE FIRE DEPT.		
Product: WD1OU-1300		
Title: CAVITY CLEARANCES - TIMBER		
Drawn: SR	Date: 31/05/2018	
Chkd: JW	Date: 31/05/2018	
Appd: JW	Date: 31/05/2018	
Scale:		on A4



Drawing No.	WD1OU-1300-903	Sheet 03 of 14	Revision 4
-------------	-----------------------	----------------	--

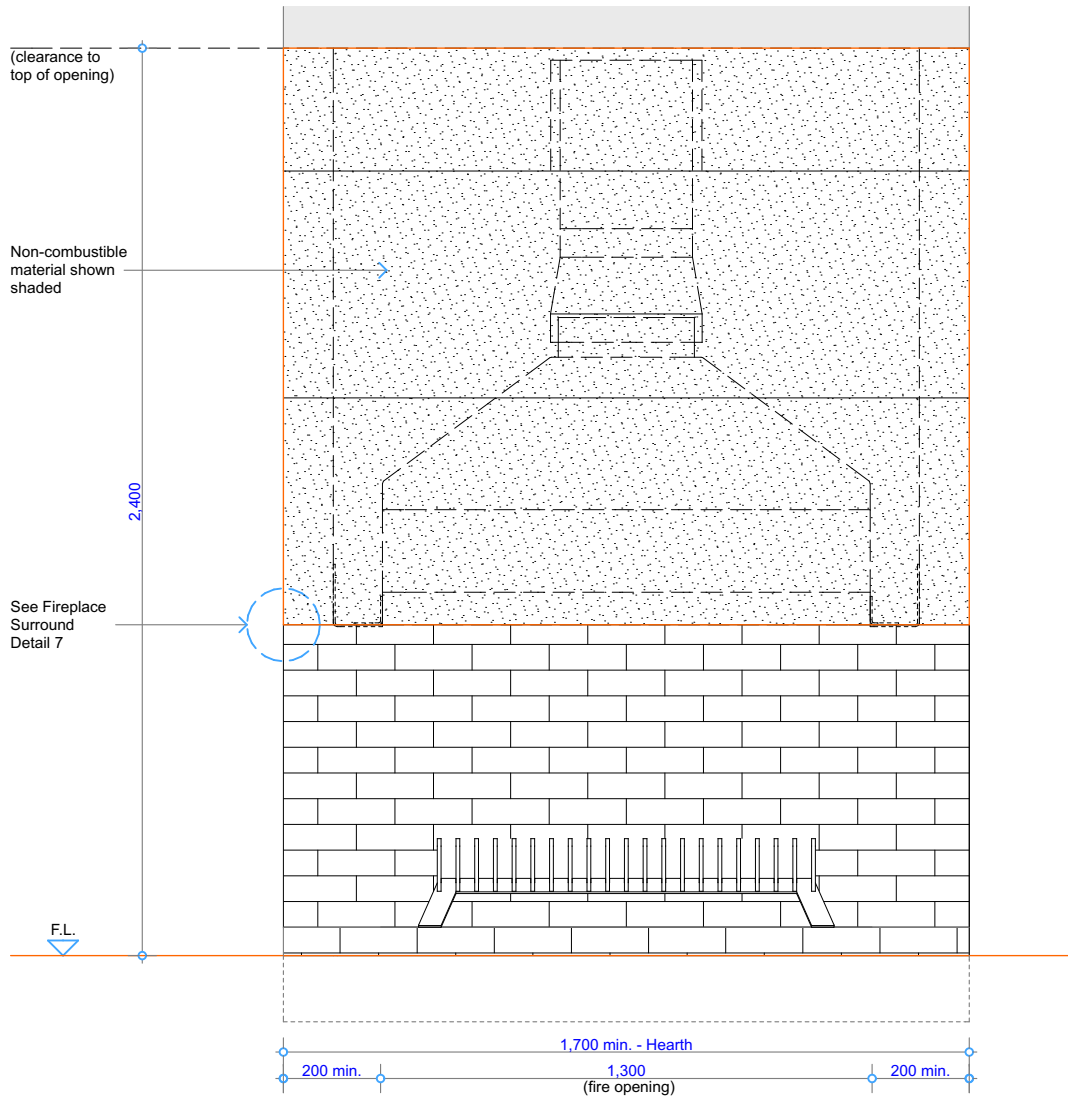

Front View - Fire Insert

COPYRIGHT©
 THIS DRAWING IS THE PROPERTY
 OF **The Fire Dept.**

Client: THE FIRE DEPT.

Product: WD1OU-1300

Title: CAVITY CLEARANCES - TIMBER

Drawn: SR

Date: 31/05/2018

Chkd: JW

Date: 31/05/2018

Appd: JW

Date: 31/05/2018

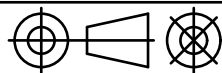

Scale: on A4

THE FIRE DEPT.

Drawing No. **WD1OU-1300-904**

Sheet 04 of 14

Revision

4

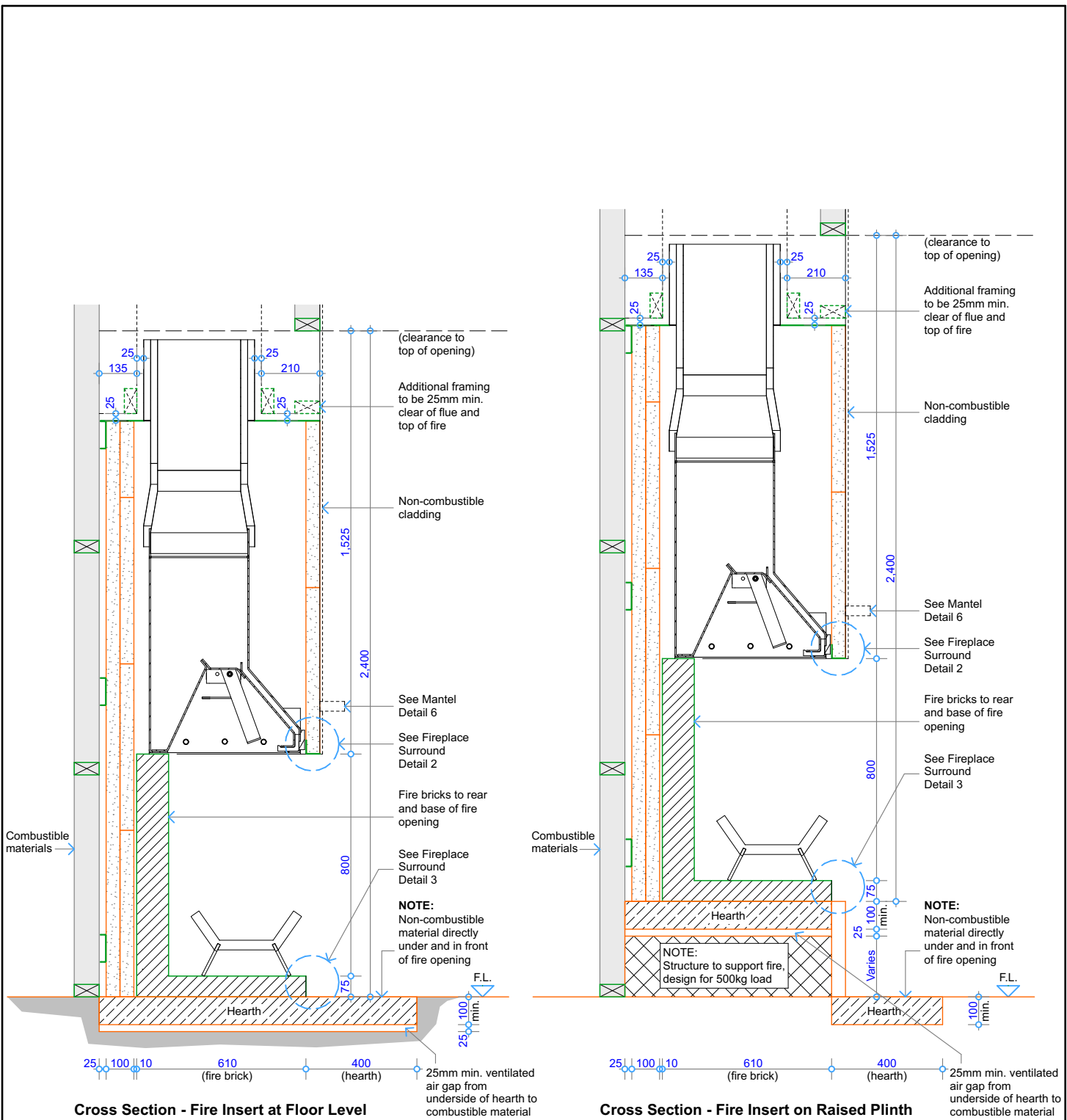

NOTE:
Non-combustible material directly under and in front of fire opening

NOTE:
Structure to support fire, design for 500kg load

NOTE:
Non-combustible material directly under and in front of fire opening

NOTE:
Room requires air inlet equal to 100,000mm².

COPYRIGHT © THIS DRAWING IS THE PROPERTY OF The Fire Dept.	Client: THE FIRE DEPT.			
	Product: WD10U-1300			
	Title: CAVITY CLEARANCES - TIMBER			
	Drawn: SR	Date: 31/05/2018		
	Chkd: JW	Date: 31/05/2018		
Appd: JW	Date: 31/05/2018	Scale: on A4		
Drawing No.	WD10U-1300-905		Sheet 05 of 14	Revision 4

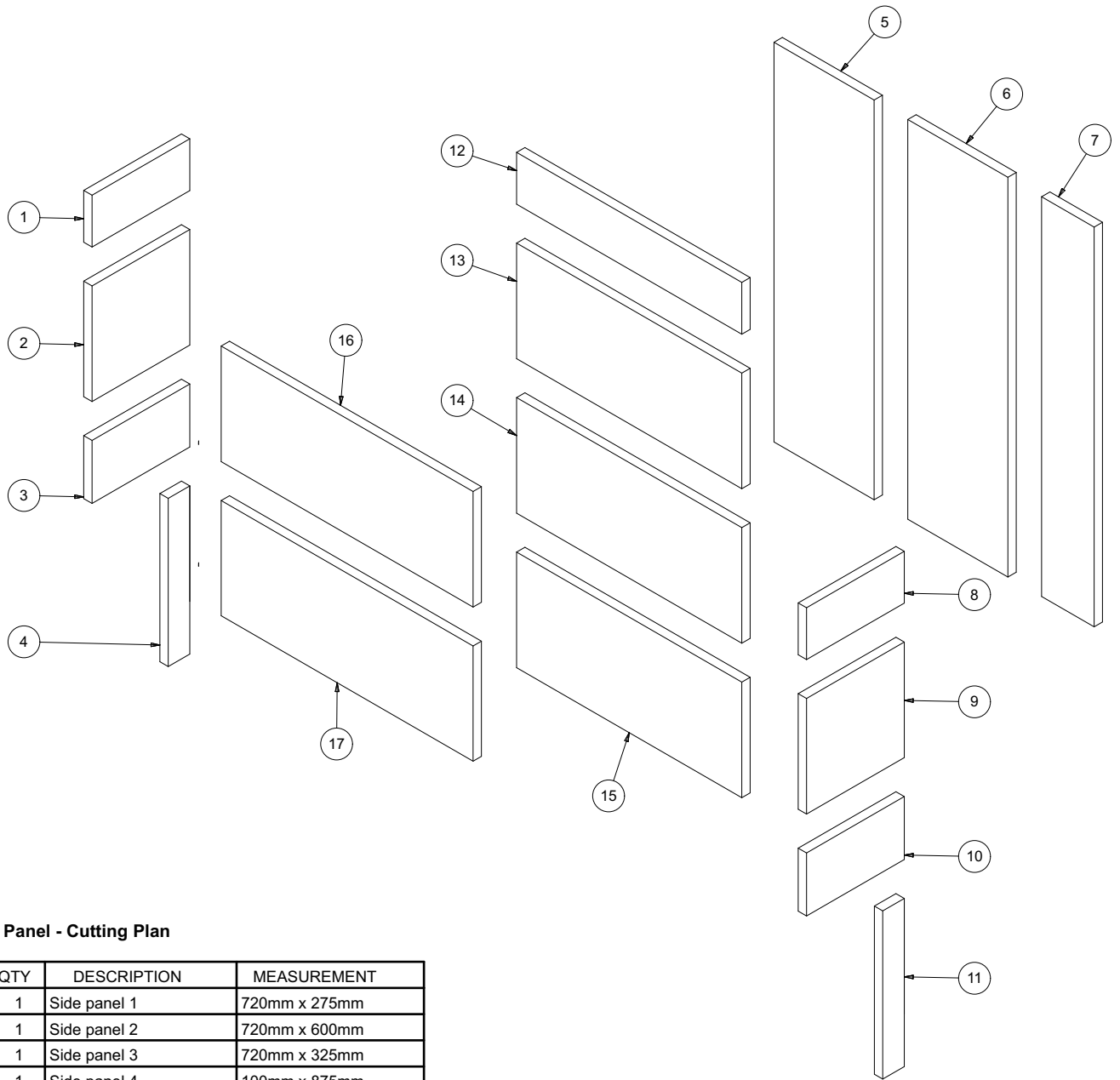

Celcrete Panel - Cutting Plan

ITEM	QTY	DESCRIPTION	MEASUREMENT
1	1	Side panel 1	720mm x 275mm
2	1	Side panel 2	720mm x 600mm
3	1	Side panel 3	720mm x 325mm
4	1	Side panel 4	100mm x 875mm
5	1	Back panel 1	600mm x 2075mm
6	1	Back panel 2	600mm x 2075mm
7	1	Back panel 3	350mm x 2075mm
8	1	Side panel 5	720mm x 275mm
9	1	Side panel 6	720mm x 600mm
10	1	Side panel 7	720mm x 325mm
11	1	Side panel 8	100mm x 875mm
12	1	Back panel 4	275mm x 1550mm
13	1	Back panel 5	600mm x 1550mm
14	1	Back panel 6	600mm x 1550mm
15	1	Back panel 7	600mm x 1550mm
16	1	Front panel 1	600mm x 1810mm
17	1	Front panel 2	600mm x 1810mm
18		Panel not required	
19		Panel not required	

COPYRIGHT©
 THIS DRAWING IS THE PROPERTY
 OF The Fire Dept.

Client: THE FIRE DEPT.		
Product: WD1OU-1300		
Title: CELCRETE CUTTING PLAN - TIMBER CAVITY		
Drawn: SR	Date: 31/05/2018	
Chkd: JW	Date: 31/05/2018	
Appd: JW	Date: 31/05/2018	
Scale:		on A4



Drawing No.	WD1OU-1300-906	Sheet 06 of 14	Revision 4
-------------	-----------------------	----------------	--

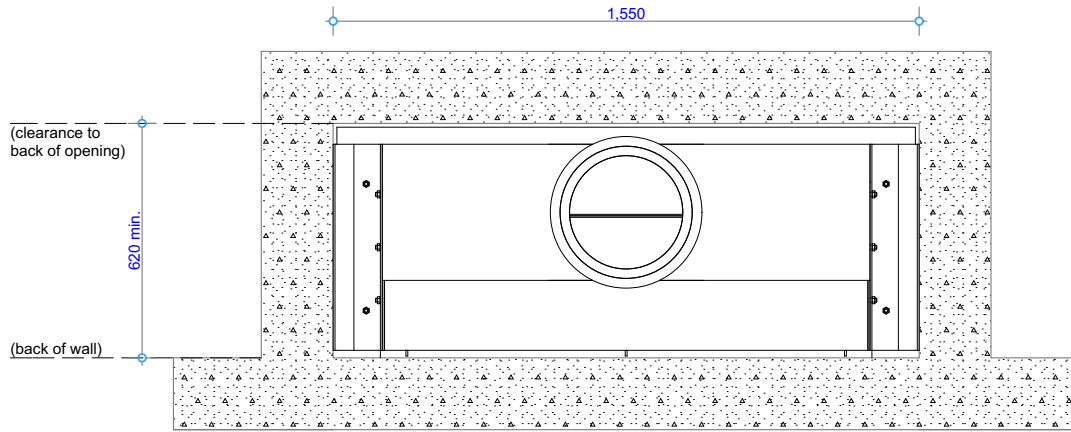

Plan View - Fire Insert (above fire gather)

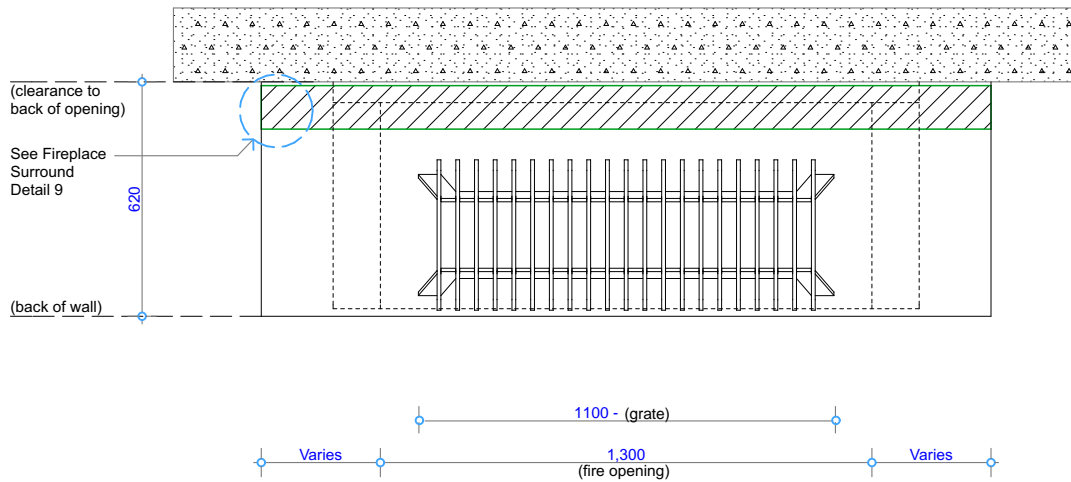

Plan View - Fire Insert (below fire gather)

COPYRIGHT©
 THIS DRAWING IS THE PROPERTY
 OF The Fire Dept.

Client: THE FIRE DEPT.		
Product: WD1OU-1300		
Title: CAVITY CLEARANCES - CONCRETE		
Drawn: SR	Date: 31/05/2018	
Chkd: JW	Date: 31/05/2018	
Appd: JW	Date: 31/05/2018	
Scale:		on A4

THE
 FIRE
 DEPT.

Drawing No. **WD1OU-1300-907**

Sheet 07 of 14

Revision

4

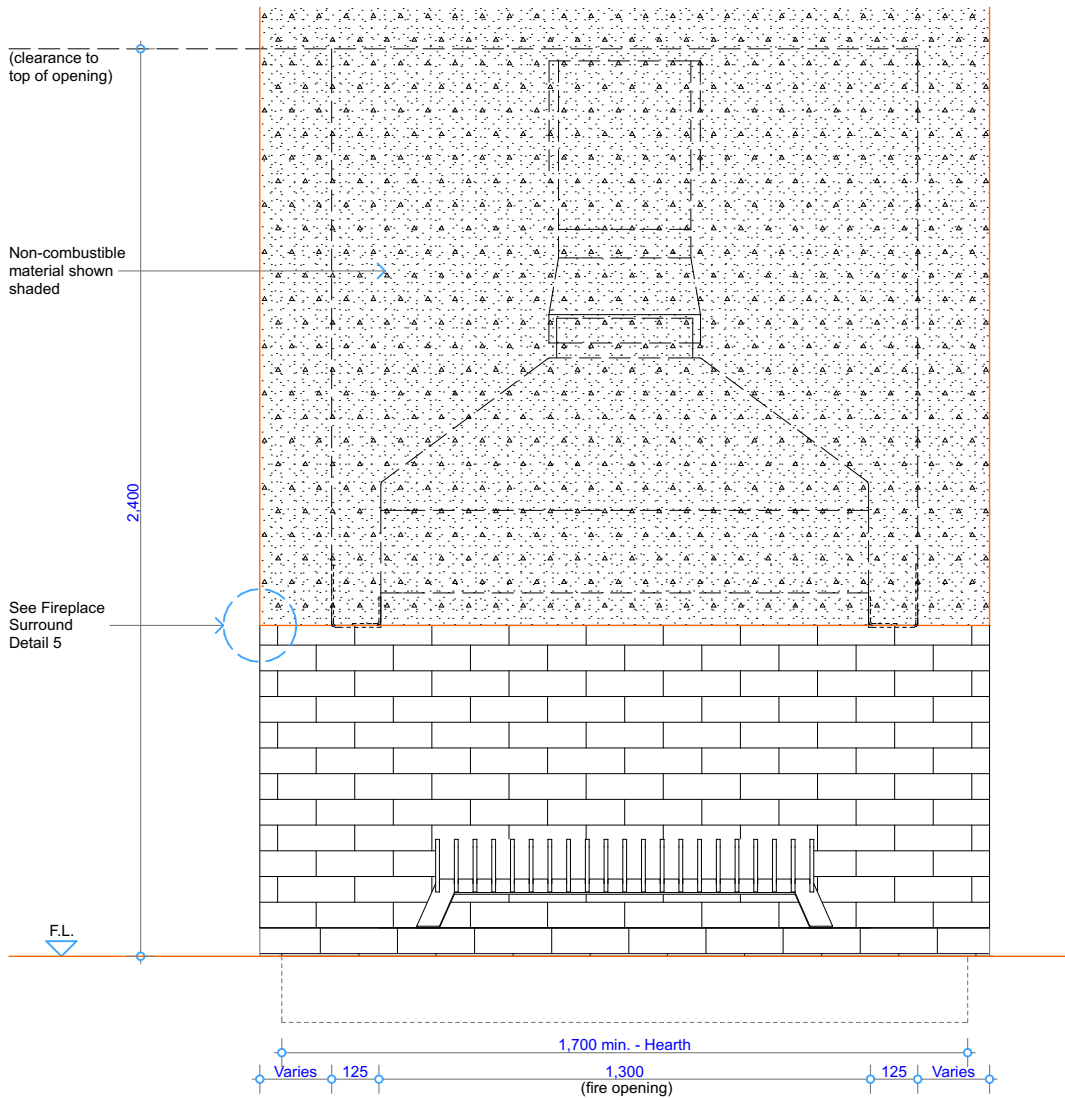

Front View - Fire Insert

COPYRIGHT©
THIS DRAWING IS THE PROPERTY
OF The Fire Dept.

Client: THE FIRE DEPT.

Product: WD10U-1300

Title: CAVITY CLEARANCES - CONCRETE

Drawn: SR

Date: 31/05/2018

Chkd: JW

Date: 31/05/2018

Appd: JW

Date: 31/05/2018

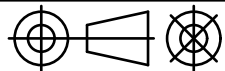

Scale: on A4

THE
**FIRE
DEPT.**

Drawing No. **WD10U-1300-908**

Sheet 08 of 14

Revision

4

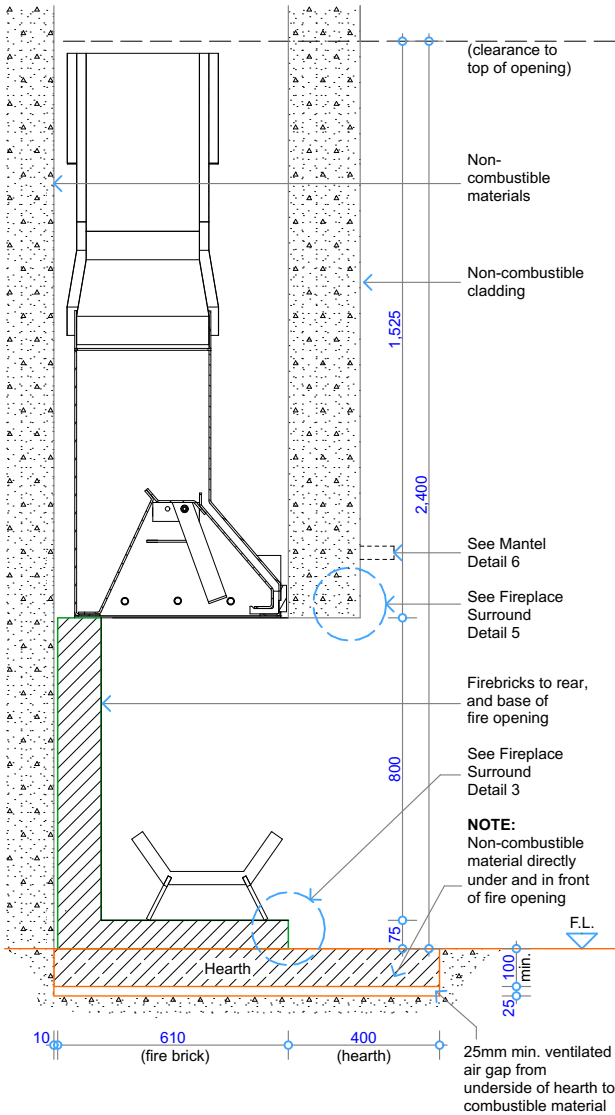

Cross Section - Fire Insert at Floor Level

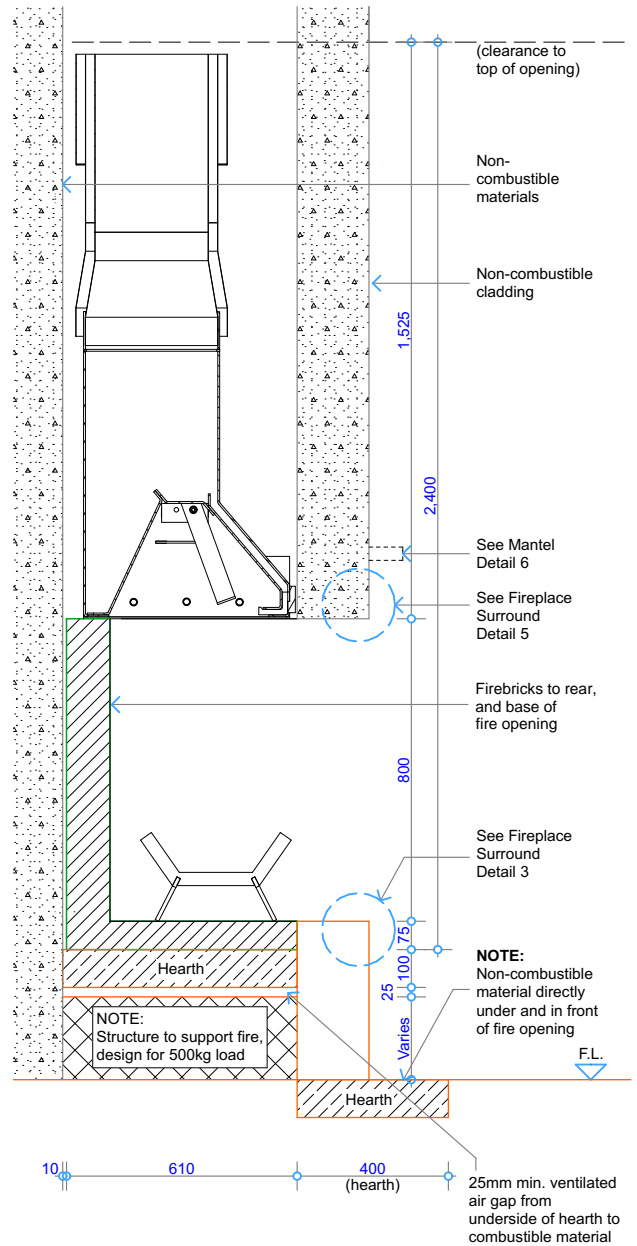

Cross Section - Fire Insert at Floor Level

NOTE:
Room requires air inlet
equal to 100,000mm².

COPYRIGHT©
THIS DRAWING IS THE PROPERTY
OF The Fire Dept.

Client: THE FIRE DEPT.

Product: WD10U-1300

Title: CAVITY CLEARANCES - CONCRETE

Drawn: SR

Date: 31/05/2018

Chkd: JW

Date: 31/05/2018

Appd: JW

Date: 31/05/2018

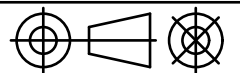

Scale: on A4

THE
**FIRE
DEPT.**

Drawing No. **WD10U-1300-909**

Sheet 09 of 14

Revision

4

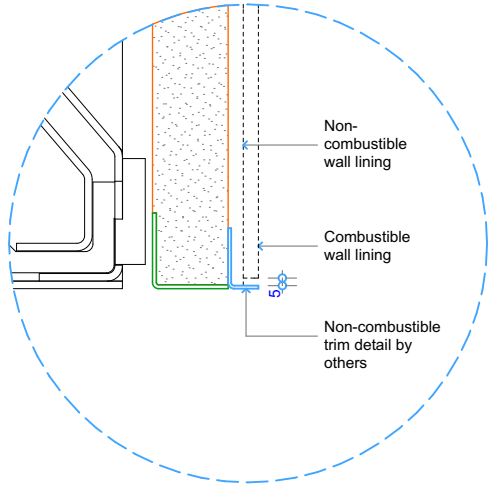

**Detail 2 - Cross Section Fire Surround Opt. 3
Timber Cavity**

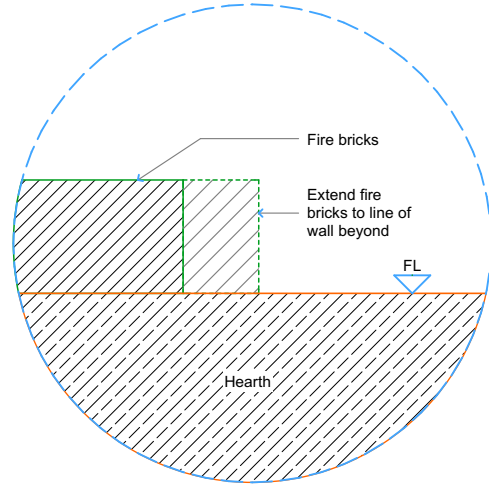

**Detail 3 - Cross Section Fire Surround Opt. 4
Timber Cavity**

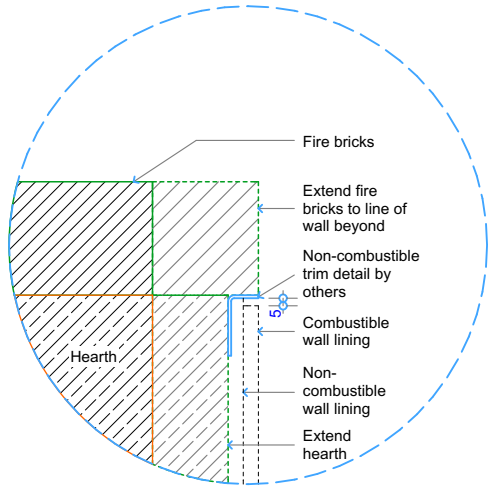

**Detail 3 - Cross Section Fire Surround Opt. 5
Timber Cavity**

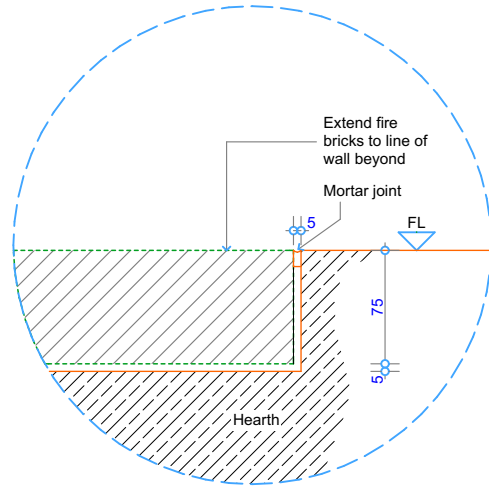

**Detail 3 - Cross Section Fire Surround Opt. 6
Concrete Cavity**

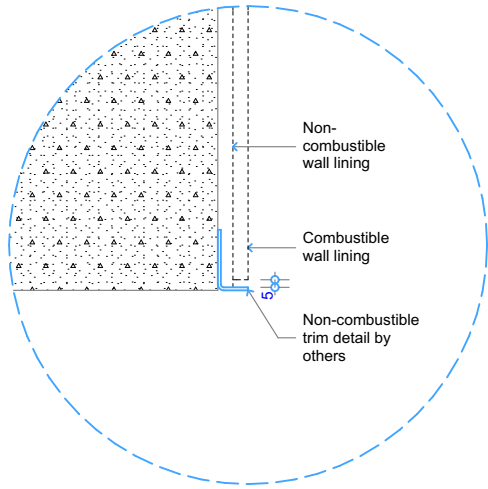

**Detail 5 - Cross Section Fire Surround Opt. 9
Concrete Cavity**

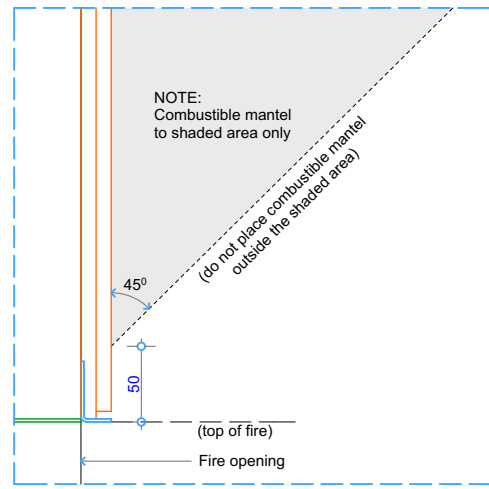

Detail 6 - Top of Fire to Combustible Mantel

COPYRIGHT© THIS DRAWING IS THE PROPERTY OF The Fire Dept.	Client: THE FIRE DEPT.			
	Product: WD10U-1300			
	Title: SURROUND DETAILS			
	Drawn: SR	Date: 31/05/2018		
	Chkd: JW	Date: 31/05/2018		
Appd: JW	Date: 31/05/2018	Scale: on A4		
Drawing No.	WD10U-1300-910		Sheet 10 of 14	Revision 4

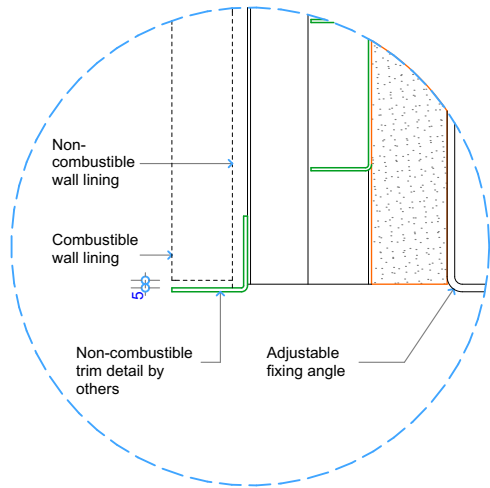

Detail 7 - Cross Section Fire Surround Timber Cavity

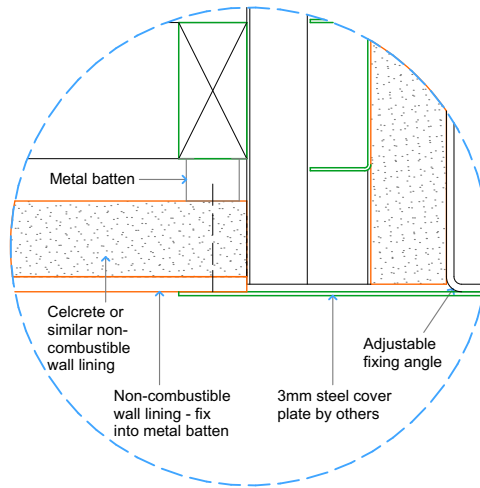

Detail 7 - Cross Section Fire Surround Opt. 14 Timber Cavity

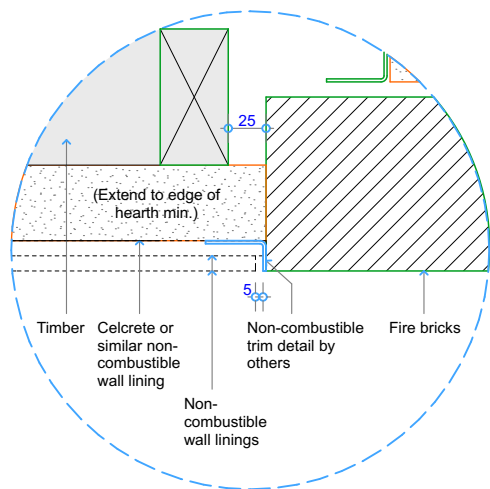

Detail 8 - Plan View Fire Surround Opt. 10 Timber Cavity

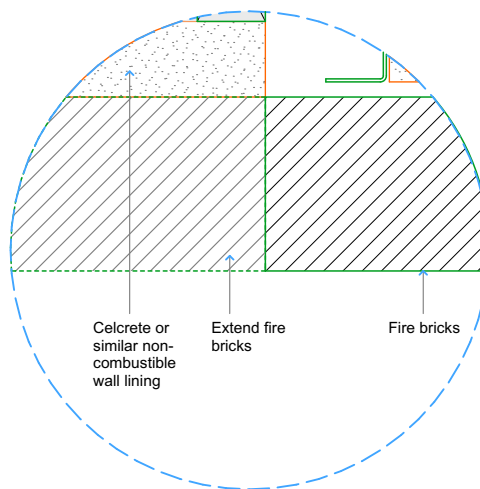

Detail 8 - Plan View Fire Surround Opt. - 11 Timber Cavity

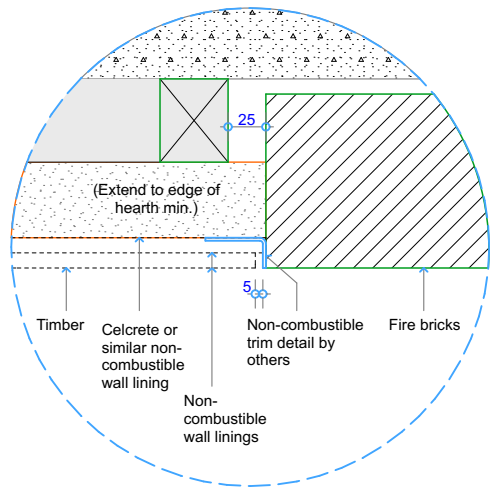

Detail 9 - Plan View Fire Surround Opt. - 12 Concrete Cavity

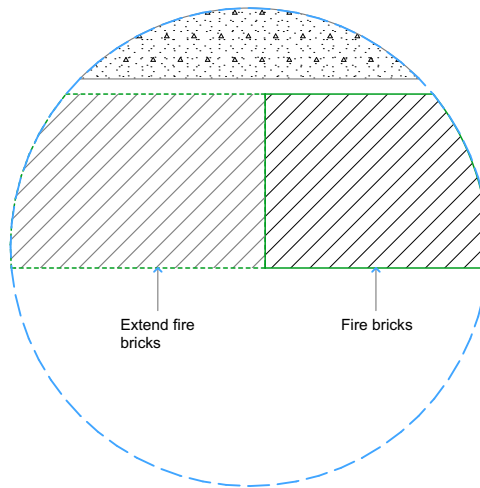

Detail 9 - Plan View Fire Surround Opt. - 13 Concrete Cavity

COPYRIGHT ©
 THIS DRAWING IS THE PROPERTY
 OF **The Fire Dept.**

Client: THE FIRE DEPT.		
Product: WD10U-1300		
Title: SURROUND DETAILS		
Drawn: SR	Date: 31/05/2018	
Chkd: JW	Date: 31/05/2018	
Appd: JW	Date: 31/05/2018	
Scale:		on A4



Drawing No.	WD10U-1300-911	Sheet 11 of 14	Revision 4
-------------	-----------------------	----------------	--

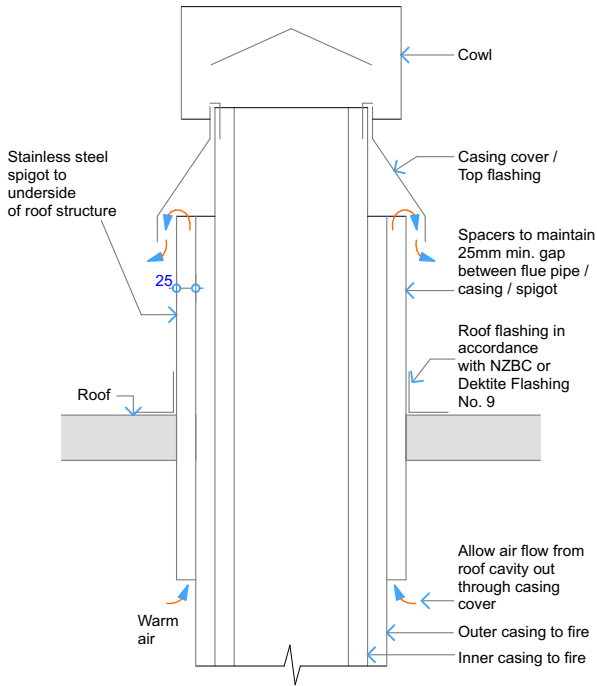

Detail Roof - Air Ventilation through Casing cover/ Top flashing

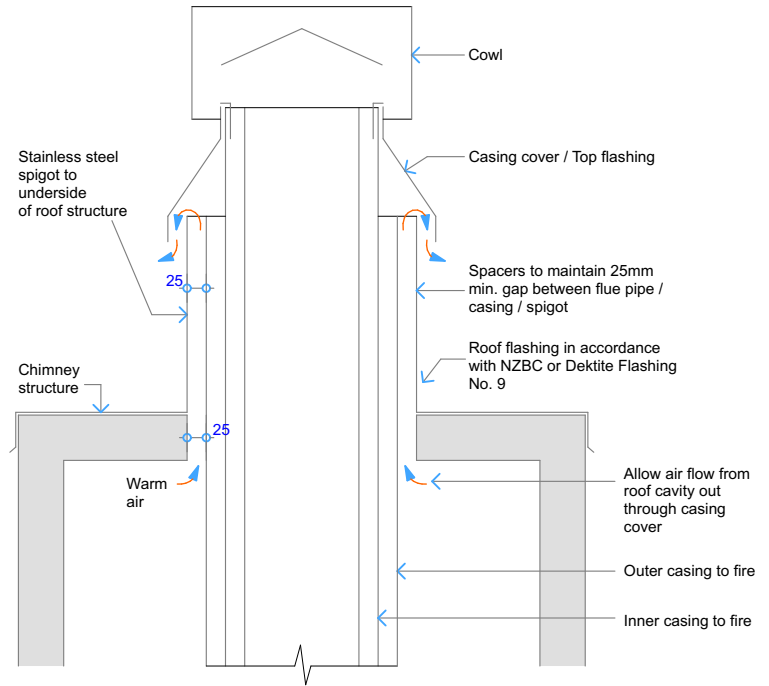

Detail Chimney - Air Ventilation through Casing cover/ Top flashing Opt. 2

Flue components:
 300mm dia. Flue
 350mm dia. Inner Casing
 400mm dia. Outer Casing
 450mm dia. S/S Spigot
 Deklite Flashing No. 9

NOTE:
 Flue components must be installed to AS/NZS2918:2001 requirements.
 All external penetration flashings must be installed in accordance with NZBC.
 Cavity airflow must be unobstructed from fire box to flue termination.
 25mm clearance between flue and combustible materials.
 75mm clearance between flue and wiring / plastic water pipes.
 Each flue joint must be sealed with a heat proof sealer.
 Each flue joint must have a minimum of 4 x Stainless Steel rivets.
 Flue to be adequately supported at 2.4m crs.

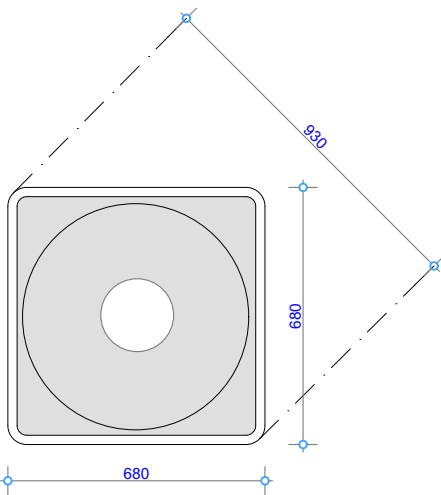

Deklite Flashing No. 9 - Plan View

COPYRIGHT ©
 THIS DRAWING IS THE PROPERTY
 OF The Fire Dept.

Client: THE FIRE DEPT.

Product: WD10U-1300

Title: VERTICAL FLUE EXIT DETAILS

Drawn: SR

Date: 31/05/2018

Chkd: JW

Date: 31/05/2018

Appd: JW

Date: 31/05/2018

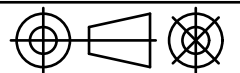

Scale: on A4



Drawing No. **WD10U-1300-912**

Sheet 12 of 14

Revision

4

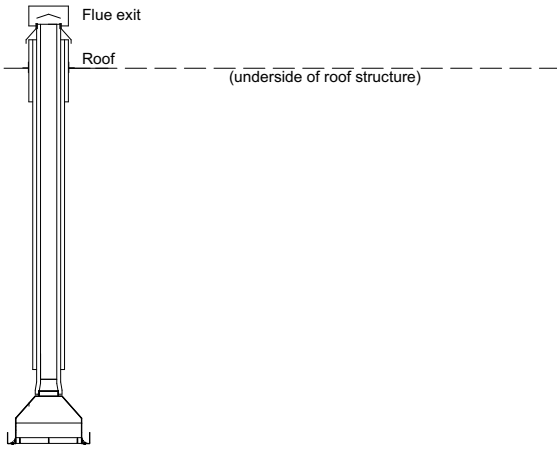

Vertical Flue Combination WD1A

NOTE:
 Flue components must be installed to AS/NZS2918:2001 requirements.
 All external penetration flashings must be installed in accordance with NZBC.
 Cavity airflow must be unobstructed from fire box to flue termination.
 25mm clearance between flue and combustible materials.
 75mm clearance between flue and wiring / plastic water pipes.
 Each flue joint must be sealed with a heat proof sealer.
 Each flue joint must have a minimum of 4 x Stainless Steel rivets.
 Flue to be adequately supported at 2m crs.

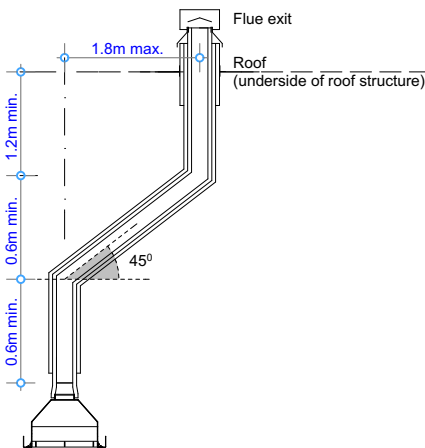

Vertical Flue Combination WD1B

NOTE:
 Flue components must be installed to AS/NZS2918:2001 requirements.
 All external penetration flashings must be installed in accordance with NZBC.
 Cavity airflow must be unobstructed from fire box to flue termination.
 25mm clearance between flue and combustible materials.
 75mm clearance between flue and wiring / plastic water pipes.
 Each flue joint must be sealed with a heat proof sealer.
 Each flue joint must have a minimum of 4 x Stainless Steel rivets.
 Flue to be adequately supported at 2m crs.

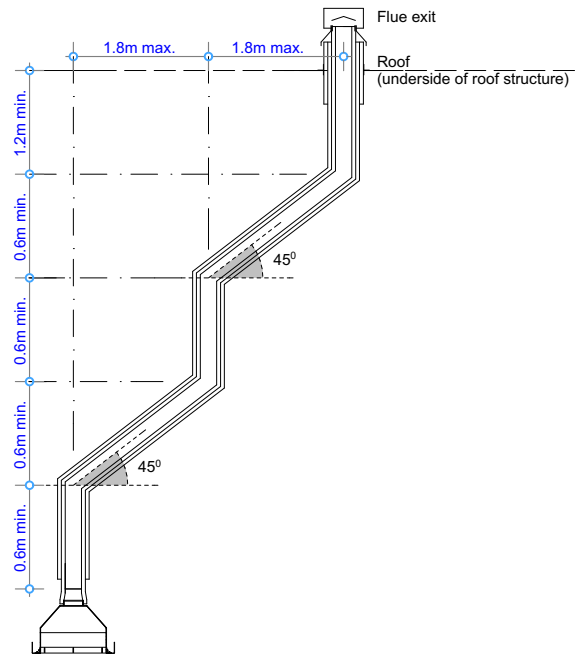

Vertical Flue Combination WD1C

NOTE:
 Flue components must be installed to AS/NZS2918:2001 requirements.
 All external penetration flashings must be installed in accordance with NZBC.
 Cavity airflow must be unobstructed from fire box to flue termination.
 25mm clearance between flue and combustible materials.
 75mm clearance between flue and wiring / plastic water pipes.
 Each flue joint must be sealed with a heat proof sealer.
 Each flue joint must have a minimum of 4 x Stainless Steel rivets.
 Flue to be adequately supported at 2m crs.

COPYRIGHT © THIS DRAWING IS THE PROPERTY OF The Fire Dept.	Client: THE FIRE DEPT.			
	Product: WD10U-1300			
	Title: VERTICAL FLUE COMBINATION OPTIONS			
	Drawn: SR	Date: 31/05/2018		
	Chkd: JW	Date: 31/05/2018		
Appd: JW	Date: 31/05/2018	Scale: on A4		
Drawing No.	WD10U-1300-913		Sheet 13 of 14	
			Revision 4	

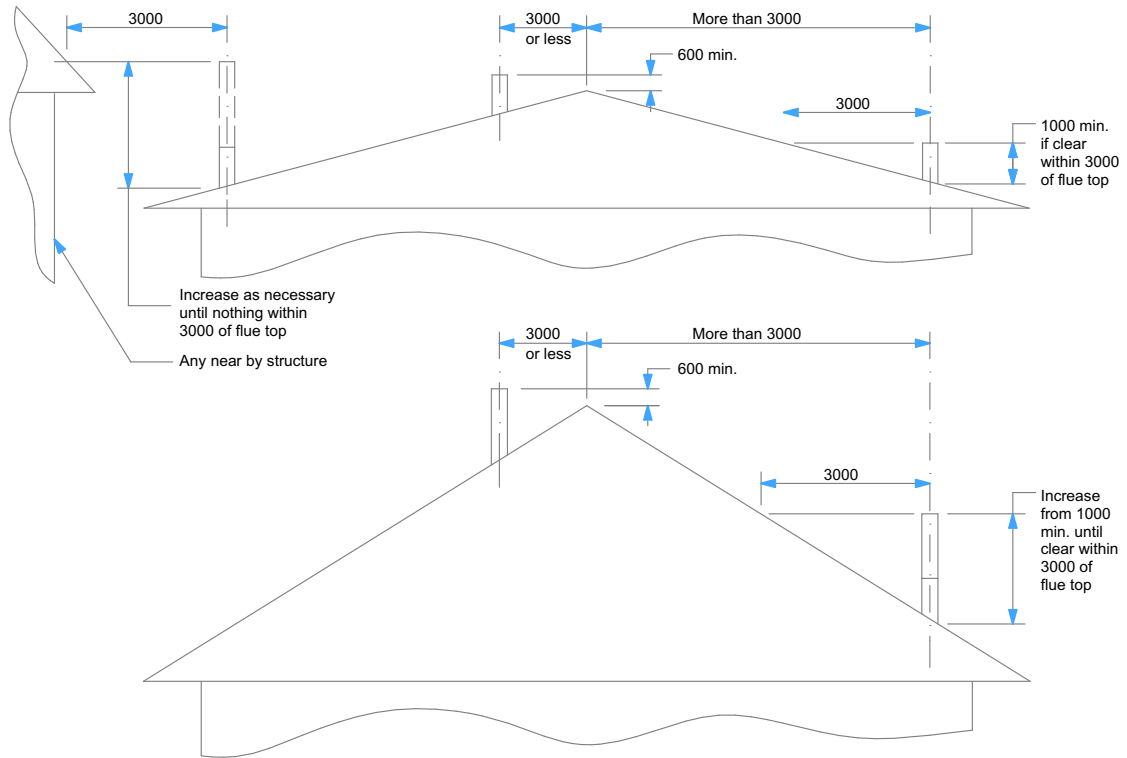

Minimum Height of Flue System Exit
Or as per AS/NZS 2918:2001

COPYRIGHT ©
 THIS DRAWING IS THE PROPERTY
 OF **The Fire Dept.**

Client: THE FIRE DEPT.		
Product: WD1OU-1300		
Title: FLUE EXIT CLEARANCES		
Drawn: SR	Date: 31/05/2018	
Chkd: JW	Date: 31/05/2018	
Appd: JW	Date: 31/05/2018	
Scale:		on A4



Drawing No.	WD1OU-1300-914	Sheet 14 of 14	Revision 4
-------------	-----------------------	----------------	--