

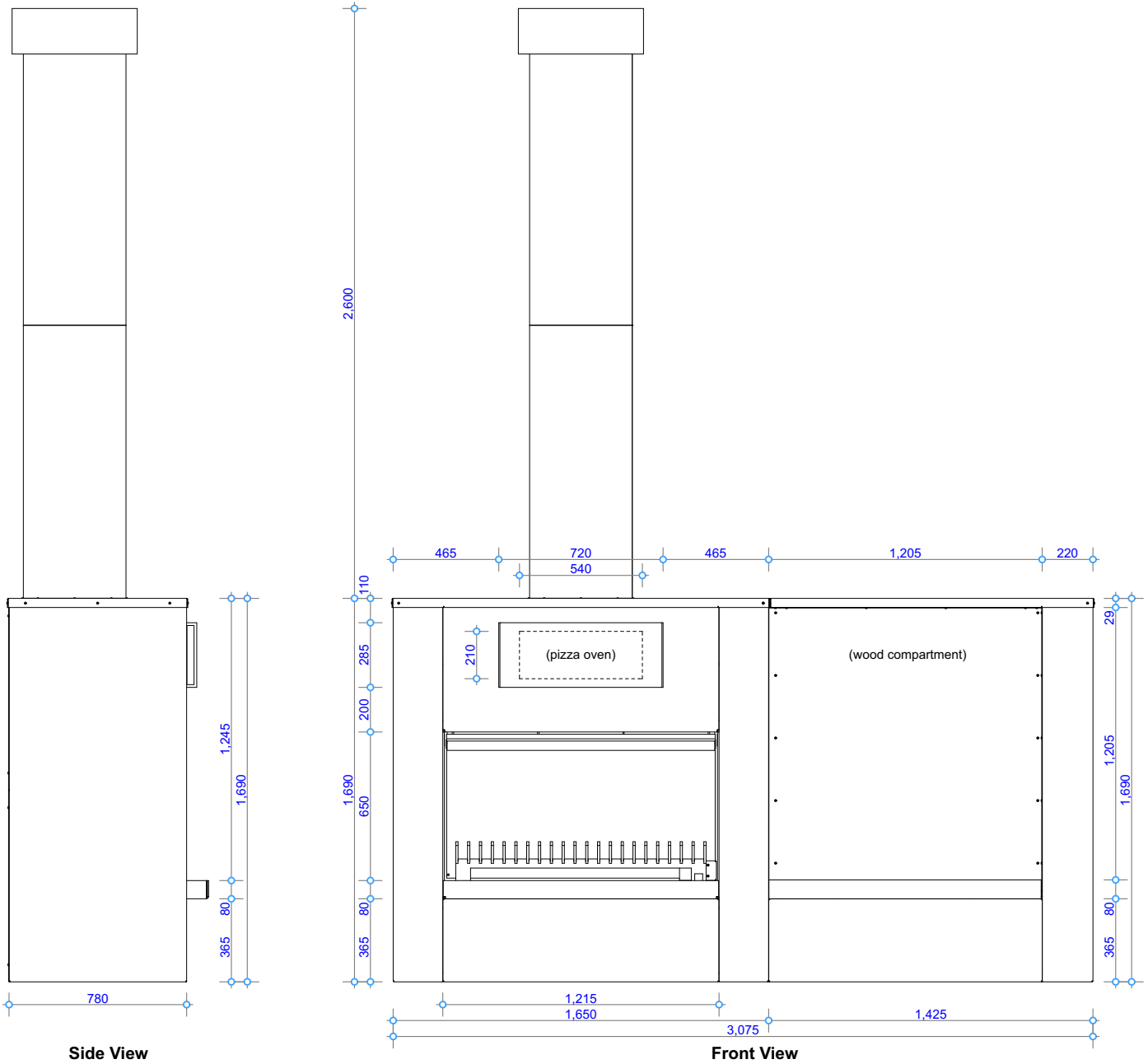

WD54

Specifications

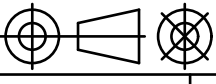

COPYRIGHT©
 THIS DRAWING IS THE PROPERTY
 OF **The Fire Dept.**

Client: THE FIRE DEPT.		
Product: WD54-1600		
Title: FIRE DIMENSIONS		
Drawn: SR	Date: 24/11/2017	
Chkd: JW	Date: 24/11/2017	
Appd: JW	Date: 24/11/2017	
Scale:		on A4



Drawing No.	WD54-1600-901	Sheet 01 of 03	Revision 0
-------------	----------------------	----------------	--

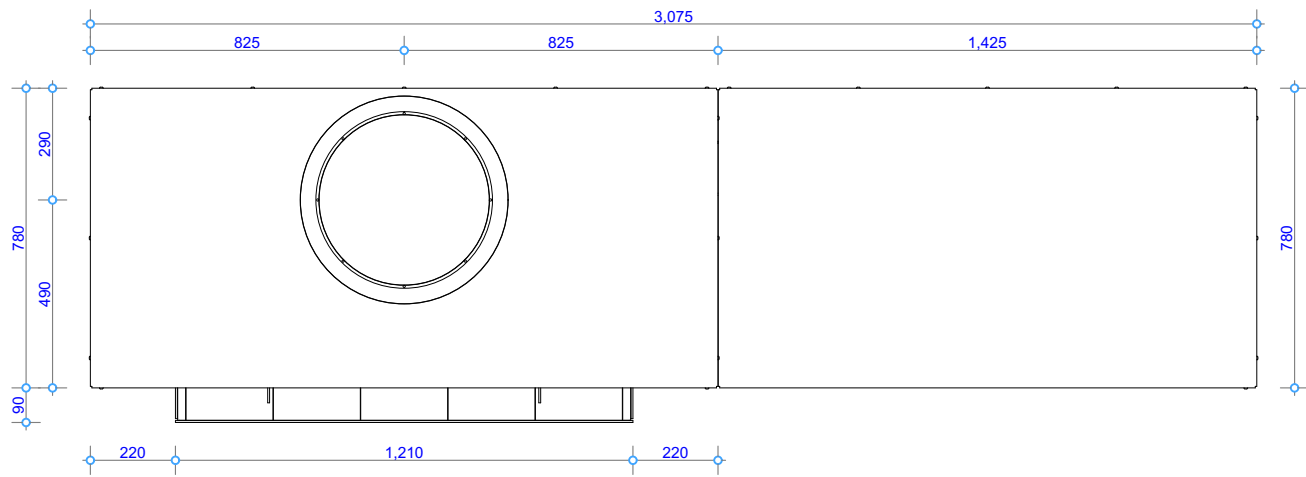

Plan View

TOLERANCE = +/- 3mm

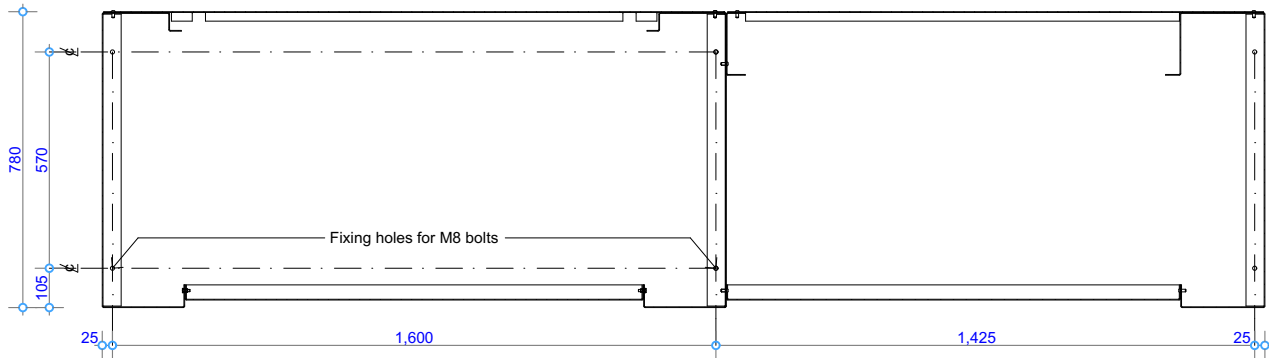

Fixing Set-out - Plan View

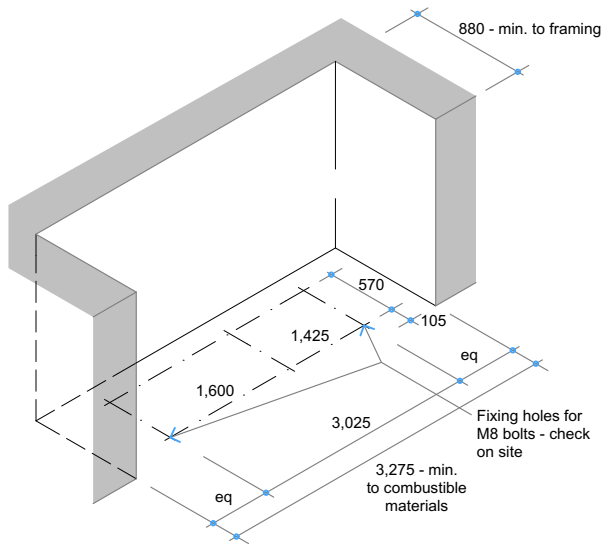

Fire Installation Requirements

NOTE: Confirm fixing holes and access on site prior to drilling. Fire place to be 100mm clear of combustible materials

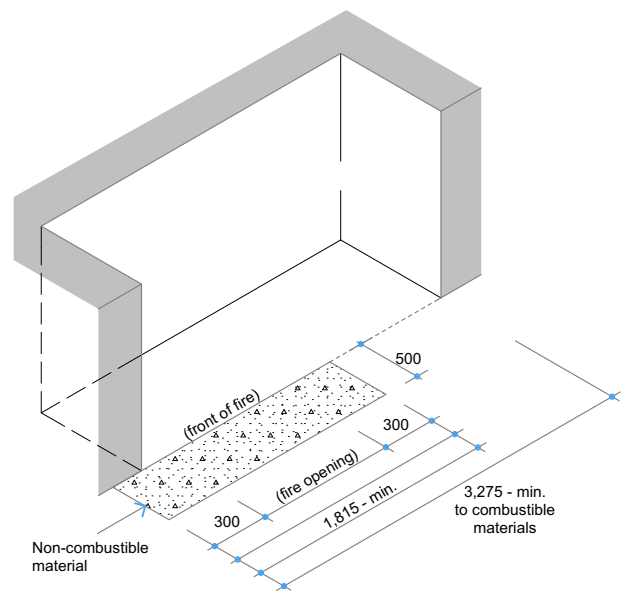

Fire Installation - Hearth Size

NOTE: Hearth to extend minimum of 300mm both sides of fire opening, and 500mm from front of fire opening

COPYRIGHT©
THIS DRAWING IS THE PROPERTY
OF The Fire Dept.

Client: THE FIRE DEPT.		
Product: WD54-1600		
Title: CAVITY CLEARANCES		
Drawn: SR	Date: 24/11/2017	
Chkd: JW	Date: 24/11/2017	
Appd: JW	Date: 24/11/2017	
Scale:		on A4



Drawing No. **WD54-1600-902**

Sheet 02 of 03

Revision 0

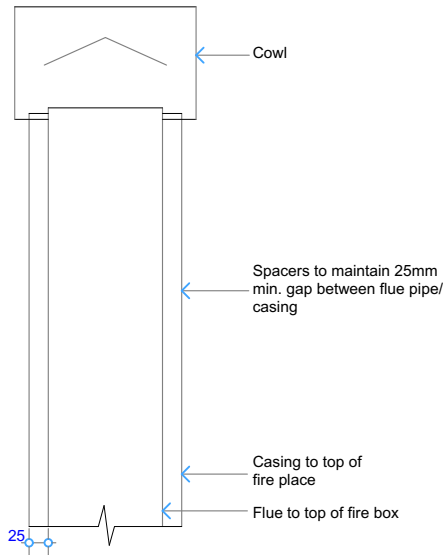

Detail - Chimney

Flue components:
 400mm dia. Flue
 450mm dia. Casing

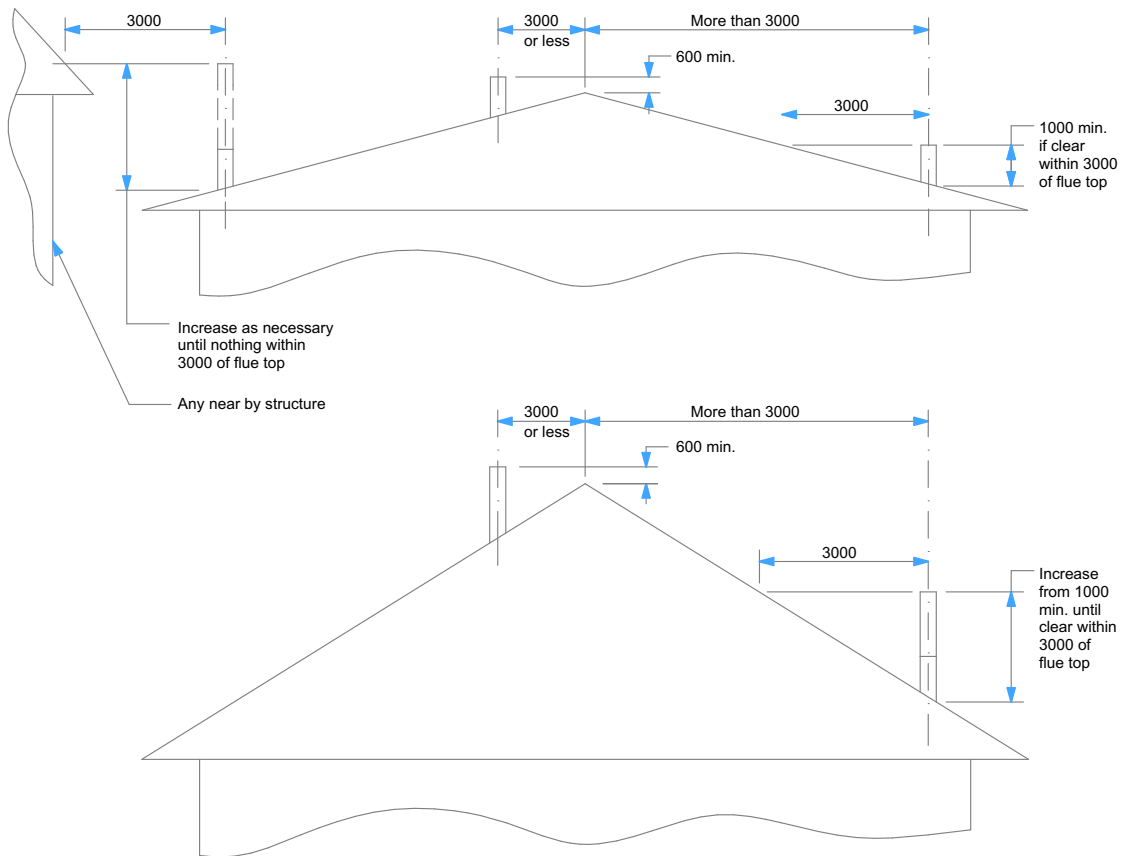

Minimum Height of Flue
 Or as per AS/NZS 2918

COPYRIGHT© THIS DRAWING IS THE PROPERTY OF The Fire Dept.	Client: THE FIRE DEPT.			
	Product: WD54-1600			
	Title: FLUE EXIT DETAILS & CLEARANCES			
	Drawn: SR	Date: 24/11/2017		
	Chkd: JW	Date: 24/11/2017		
Appd: JW	Date: 24/11/2017	Scale: on A4		
Drawing No.	WD54-1600-903		Sheet 03 of 03	Revision 0