

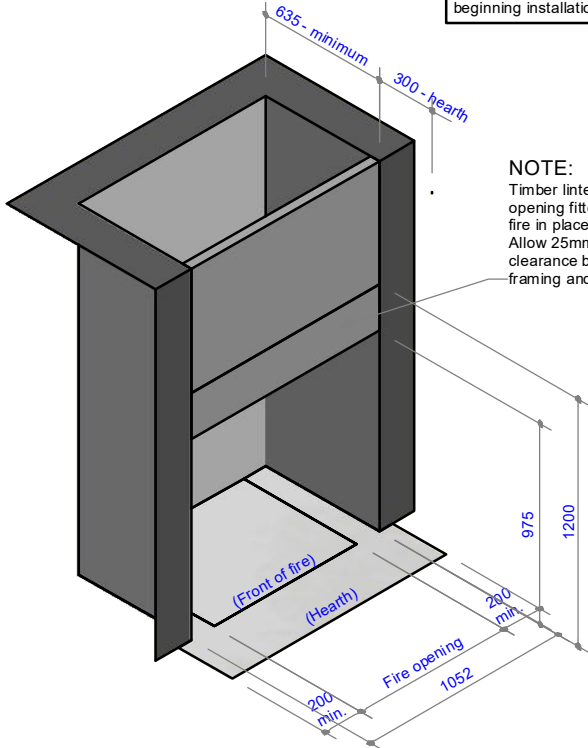

**WD6-800**

**Specifications**

Information in this specification may be subject to change without notice. Please ensure you have the current version before beginning installation.



**NOTE:**  
Timber lintel to suit opening fitted after fire in place. Allow 25mm min. clearance between framing and fire box

**Fire installation requirements & Hearth size - Timber cavity**

NOTE: Hearth to extend minimum of 200mm both sides of the fire opening, and 300mm from front of fire opening. Framed cavity must be vented at the bottom. Air inlet to be equal or greater than 15 000mm<sup>2</sup>.

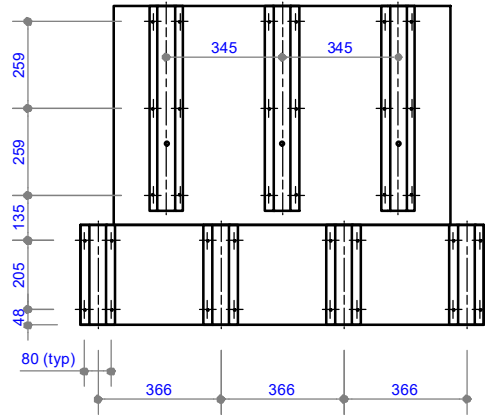

**Bottom View**

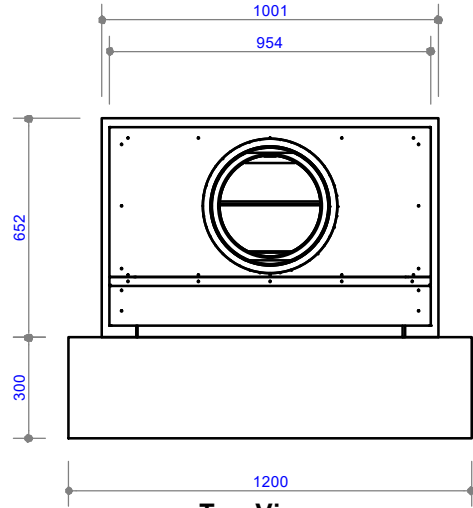

**Top View**

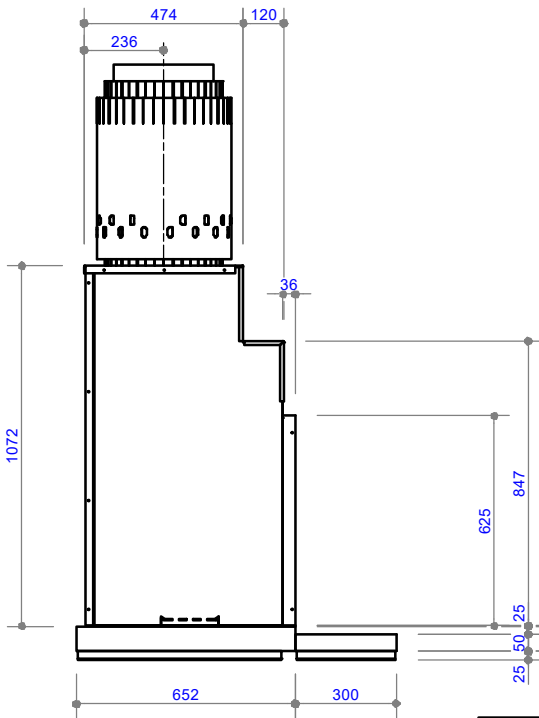

**Side View**

TOLERANCE = +/- 3mm

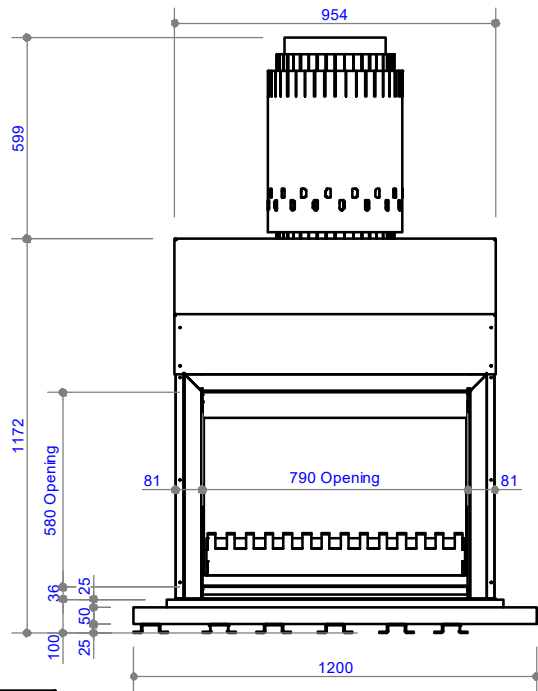

**Front View**

COPYRIGHT ©  
 THIS DRAWING IS THE PROPERTY  
 OF **The Fire Dept.**

Client: THE FIRE DEPT.

Product: WD6-0800

Title: FIRE DIMENSIONS

Drawn: J.SCHOEMAN

Date: 03/10/2018

Chkd: J. WILSON

Date: 03/10/2018

Appd: J. WILSON

Date: 03/10/2018

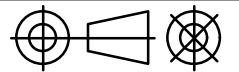

Scale: on A4



Drawing No. **WD6-0800-901**

Sheet 1 of 8

Revision **1**

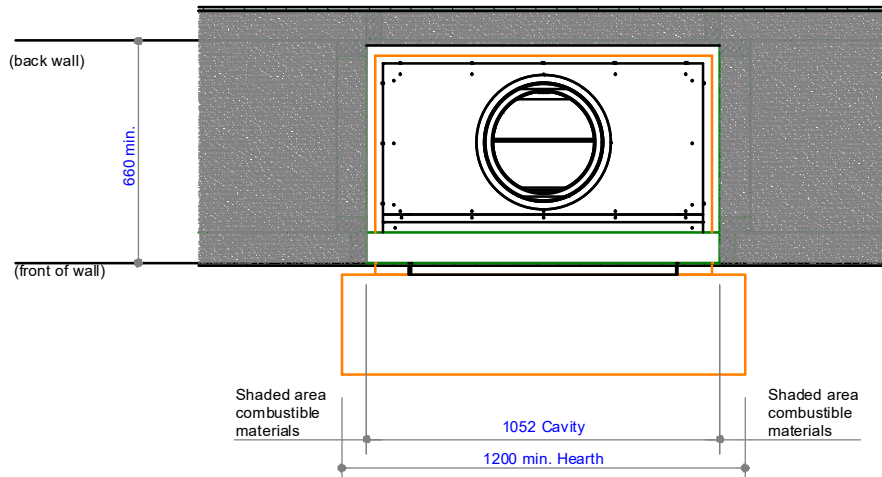

Plan View - Fire insert

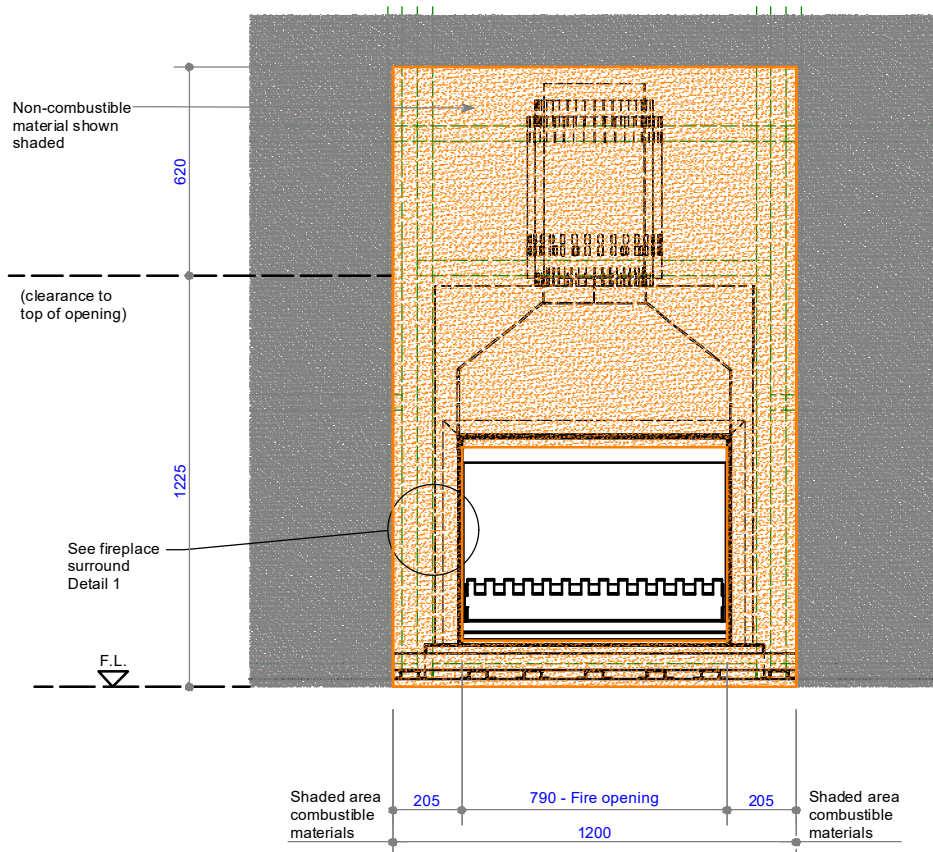

Front view - Fire insert

COPYRIGHT ©  
 THIS DRAWING IS THE PROPERTY  
 OF The Fire Dept.

Client: THE FIRE DEPT.

Product: WD6-0800

Title: CAVITY CLEARANCES - TIMBER

Drawn: J SCHOEMAN

Date: 03/10/2018

Chkd: J. WILSON

Date: 03/10/2018

Appd: J. WILSON

Date: 03/10/2018

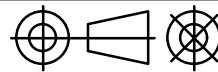

Scale: on A4



Drawing No. **WD6-0800-902**

Sheet 2 of 8

Revision **1**

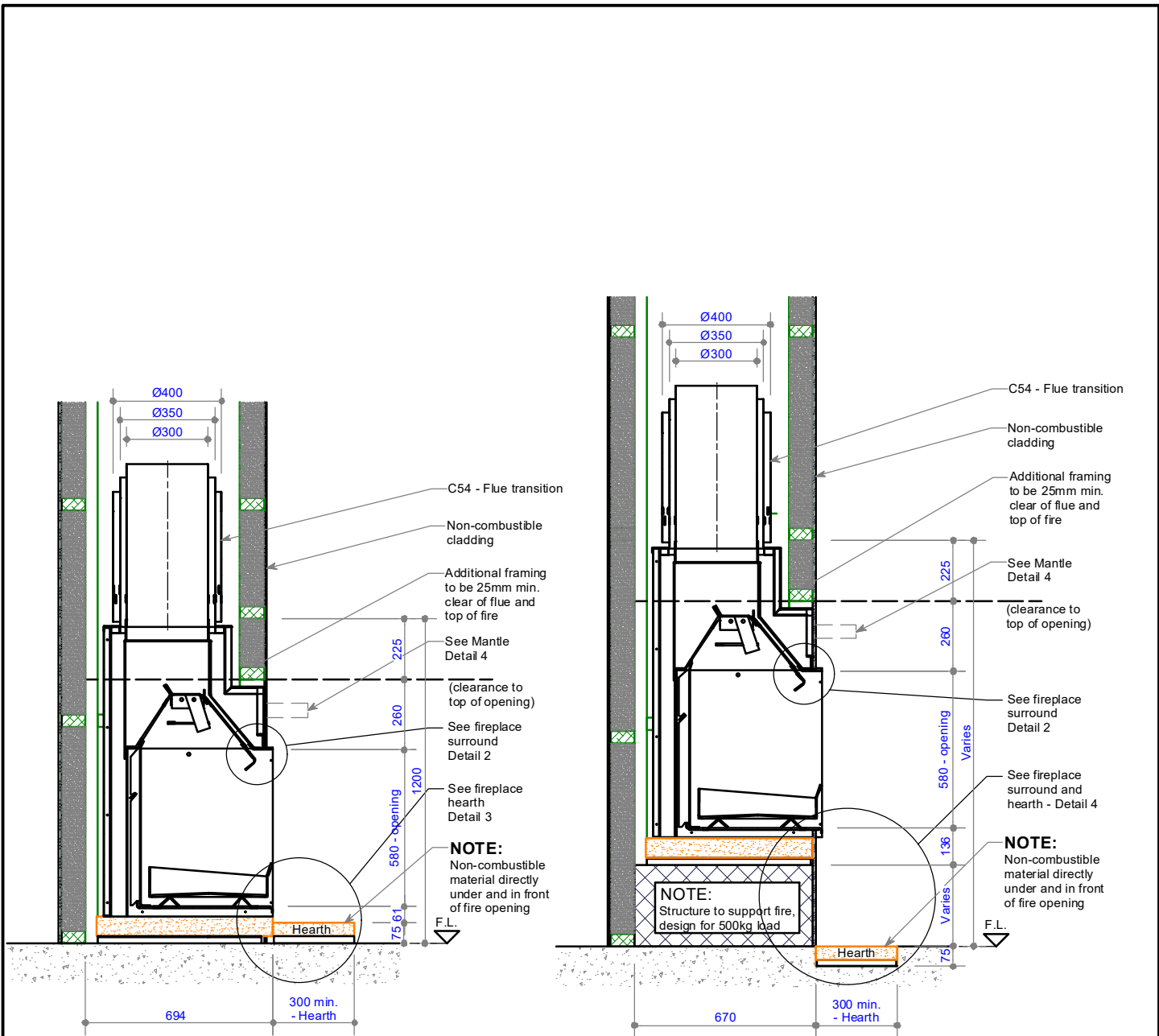

Cross Section - Fire insert at floor level

Cross Section - Fire insert at floor level

NOTE:  
Room requires air inlet  
equal to 100 000mm<sup>2</sup>

COPYRIGHT © THIS DRAWING IS THE PROPERTY OF The Fire Dept.	Client: THE FIRE DEPT.			
	Product: WD6-0800			
	Title: CAVITY CLEARANCES - TIMBER			
	Drawn: J.SCHOEMAN	Date: 03/10/2018		
	Chkd: J. WILSON	Date: 03/10/2018		
Appd: J. WILSON	Date: 03/10/2018	Scale:            on A4		
Drawing No. <b>WD6-0800-903</b>	Sheet <b>3</b> of <b>8</b>	Revision <b>1</b>		

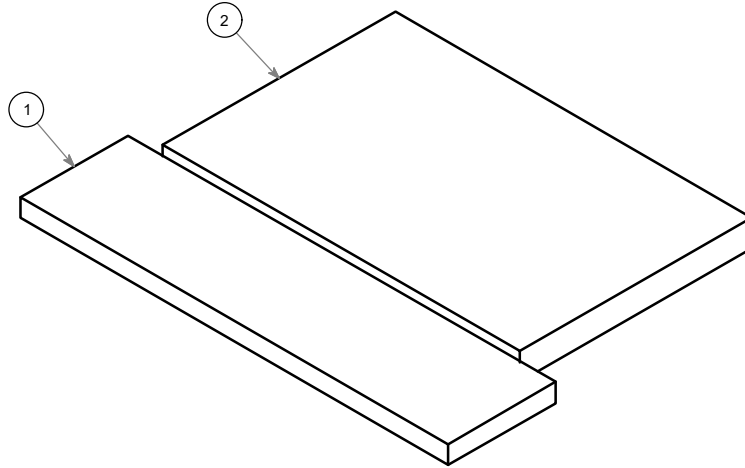

**ACC panel - Cutting plan**

ITEM	QTY	DESCRIPTION	MEASUREMENT
1	1	Hearth AAC panel	300mm x 1200mm x 50mm
2	1	Firebox base AAC panel (Fireplace flush with floor)	651mm x 1001mm x 75mm
2	1	Firebox base AAC panel (Fireplace raised above floor)	615mm x 1001mm x 75mm

COPYRIGHT ©  
 THIS DRAWING IS THE PROPERTY  
 OF **The Fire Dept.**

Client: THE FIRE DEPT.			
Product: WD6-0800			
Title: AAC PANEL CUTTING PLAN - TIMBER CAVITY			
Drawn: J.SCHOEMAN	Date: 03/10/2018		
Chkd: J. WILSON	Date: 03/10/2018		
Appd: J. WILSON	Date: 03/10/2018		
Scale:		on A4	



Drawing No. <b>WD6-0800-904</b>	Sheet 4 of 8	Revision <b>1</b>
---------------------------------	--------------	-------------------

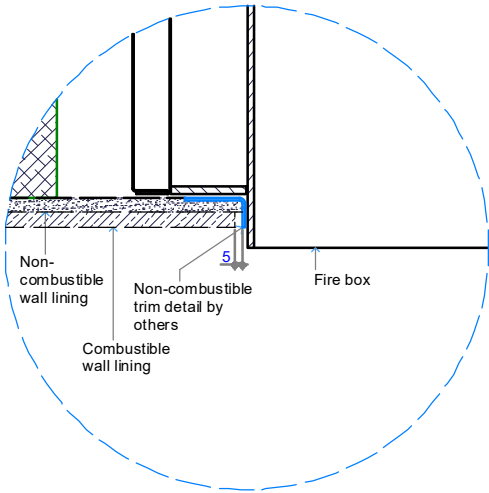

Detail 1 - Plan View Fire Surround

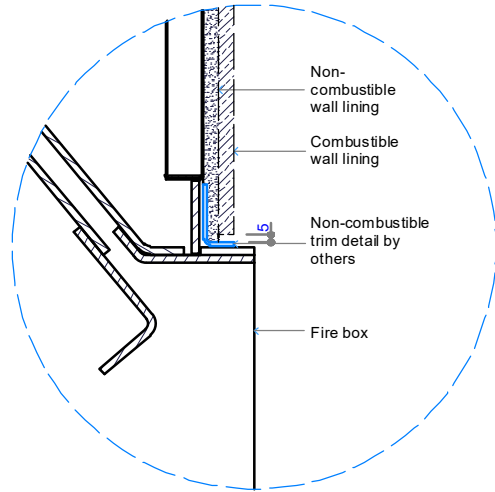

Detail 2 - Cross Section Fire Surround

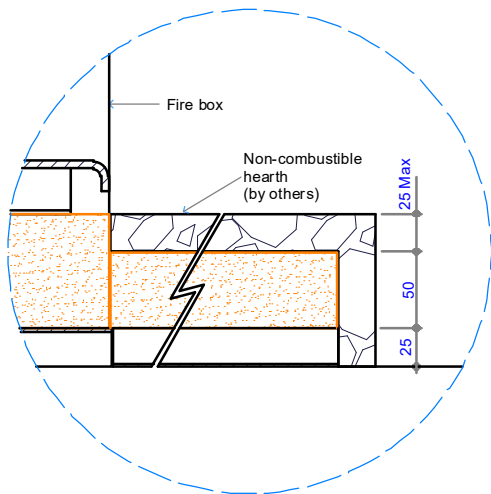

Detail 3 - Cross Section Fire hearth - Opt. 1

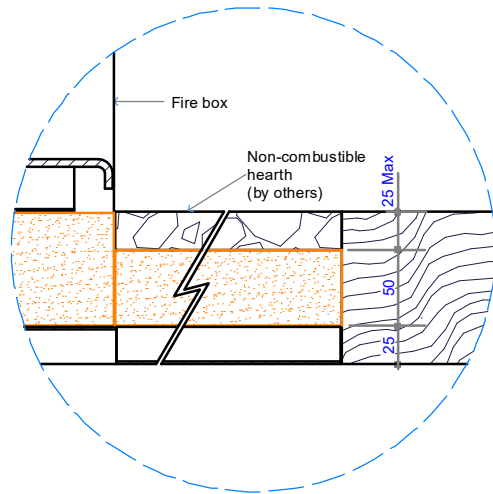

Detail 3 - Cross Section Fire hearth - Opt. 2

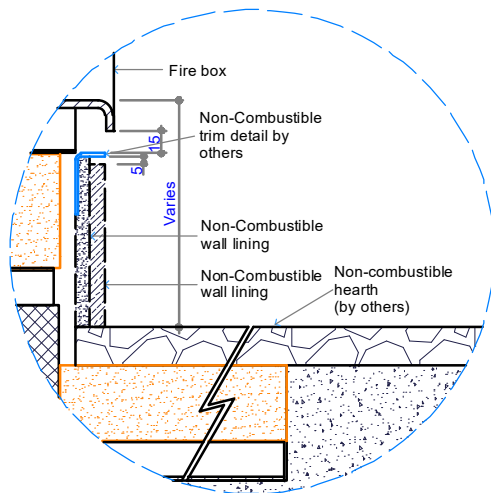

Detail 4 - Cross Section Fire Surround

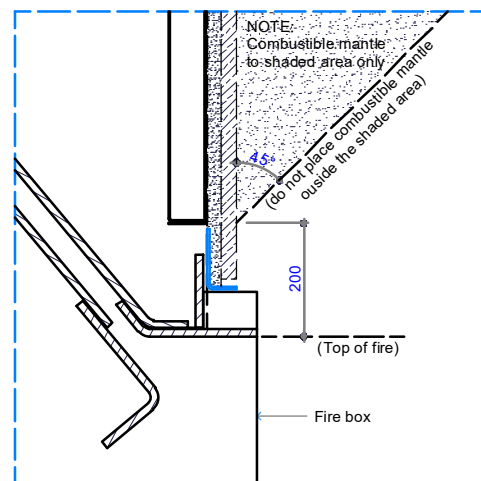

Detail 5 - Top of Fire to Combustible Mantle

COPYRIGHT ©  
 THIS DRAWING IS THE PROPERTY  
 OF **The Fire Dept.**

Client: THE FIRE DEPT.

Product: WD6-0800

Title: SURROUND DETAILS

Drawn: J.SCHOEMAN

Date: 03/10/2018

Chkd: J. WILSON

Date: 03/10/2018

Appd: J. WILSON

Date: 03/10/2018

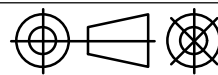

Scale: on A4

**THE FIRE DEPT.**  
**HAND CRAFTED FIRES**

Drawing No. **WD6-0800-905**

Sheet **5** of **8**

Revision **1**

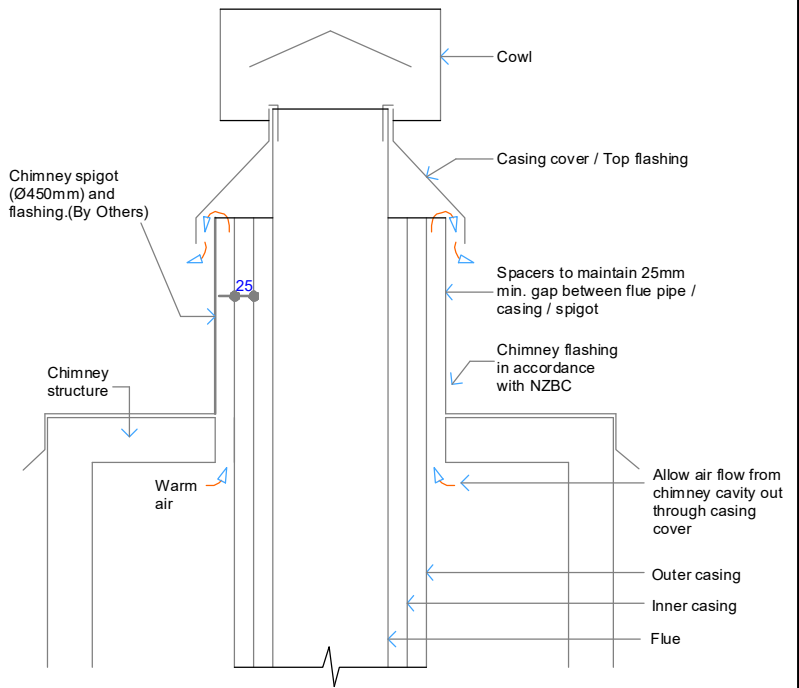
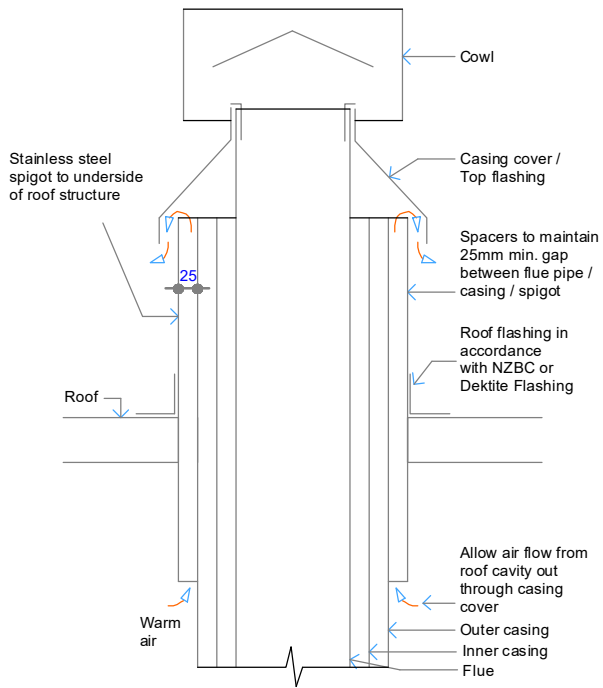

**Detail Roof - Air Ventilation through Casing cover / Top flashing**

**Detail Chimney - Air Ventilation through Casing cover / Top flashing Opt. 2**

Flue components:  
 300mm dia. Flue  
 350mm dia. Inner Casing  
 400mm dia. Outer Casing  
 450mm dia. S/S Spigot  
 Deklite Flashing No. 9

**NOTE:**  
 Flue components must be installed to AS/NZS2918:2001 requirements.  
 All external penetration flashings must be installed in accordance with NZBC.  
 Cavity airflow must be unobstructed from fire box to flue termination.  
 25mm clearance between flue and combustible materials.  
 75mm clearance between flue and wiring / plastic water pipes.  
 Each flue joint must be sealed with a heat proof sealer.  
 Each flue joint must have a minimum of 4 x Stainless Steel rivets.  
 Flue to be adequately supported at 2m crs.

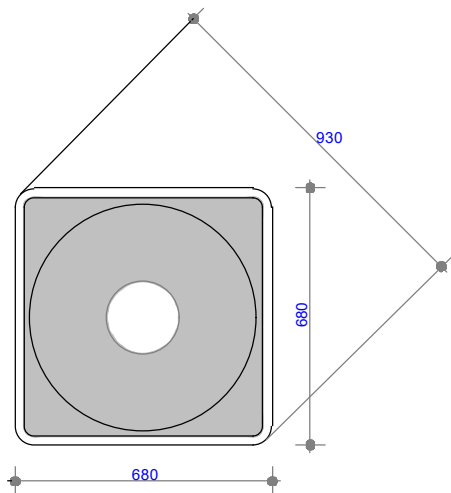

**Deklite Flashing No. 9 - Plan View**

COPYRIGHT ©  
 THIS DRAWING IS THE PROPERTY  
 OF **The Fire Dept.**

Client: THE FIRE DEPT.		
Product: WD6-0800		
Title: VERTICAL FLUE EXIT DETAILS		
Drawn: J.SCHOEMAN	Date: 03/10/2018	
Chkd: J. WILSON	Date: 03/10/2018	
Appd: J. WILSON	Date: 03/10/2018	
Scale:		on A4



Drawing No. <b>WD6-0800-906</b>	Sheet <b>6</b> of <b>8</b>	Revision <b>1</b>
---------------------------------	----------------------------	-------------------



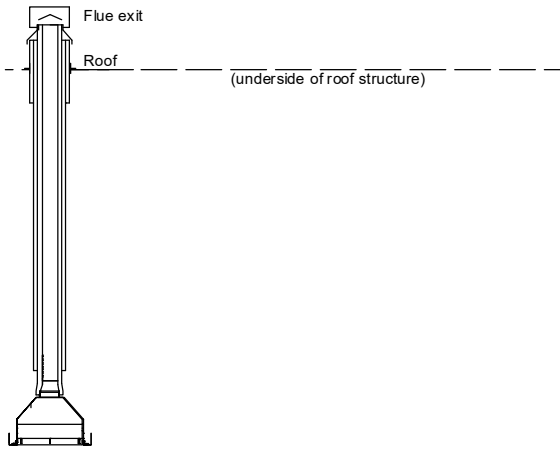

**Vertical Flue Combination WD6A**

**NOTE:**  
 Flue components must be installed to AS/NZS2918:2001 requirements.  
 All external penetration flashings must be installed in accordance with NZBC.  
 Cavity airflow must be unobstructed from fire box to flue termination.  
 25mm clearance between flue and combustible materials.  
 75mm clearance between flue and wiring / plastic water pipes.  
 Each flue joint must be sealed with a heat proof sealer.  
 Each flue joint must have a minimum of 4 x Stainless Steel rivets.  
 Flue to be adequately supported at 2m crs.

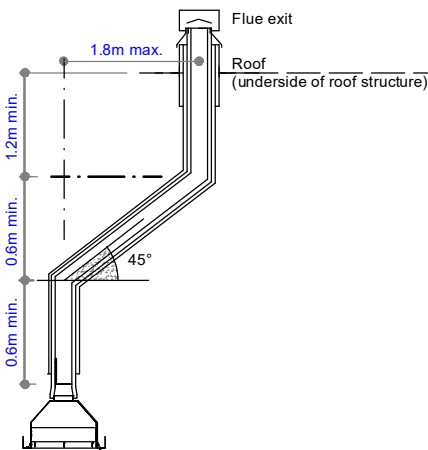

**Vertical Flue Combination WD6B**

**NOTE:**  
 Flue components must be installed to AS/NZS2918:2001 requirements.  
 All external penetration flashings must be installed in accordance with NZBC.  
 Cavity airflow must be unobstructed from fire box to flue termination.  
 25mm clearance between flue and combustible materials.  
 75mm clearance between flue and wiring / plastic water pipes.  
 Each flue joint must be sealed with a heat proof sealer.  
 Each flue joint must have a minimum of 4 x Stainless Steel rivets.  
 Flue to be adequately supported at 2m crs.

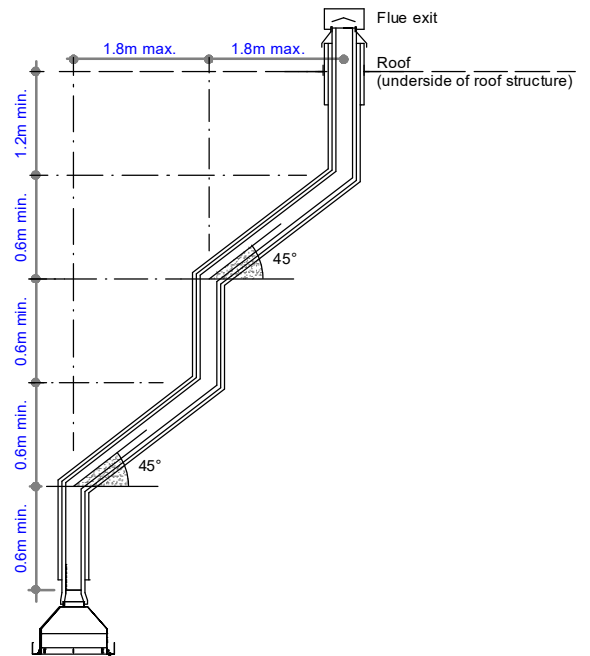

**Vertical Flue Combination WD6C**

**NOTE:**  
 Flue components must be installed to AS/NZS2918:2001 requirements.  
 All external penetration flashings must be installed in accordance with NZBC.  
 Cavity airflow must be unobstructed from fire box to flue termination.  
 25mm clearance between flue and combustible materials.  
 75mm clearance between flue and wiring / plastic water pipes.  
 Each flue joint must be sealed with a heat proof sealer.  
 Each flue joint must have a minimum of 4 x Stainless Steel rivets.  
 Flue to be adequately supported at 2m crs.

COPYRIGHT ©  
 THIS DRAWING IS THE PROPERTY  
 OF The Fire Dept.

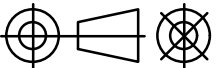
Client: THE FIRE DEPT.			
Product: WD6-0800			
Title: VERTICAL FLUE COMBINATION OPTIONS			
Drawn: J.SCHOEMAN	Date: 03/10/2018		
Chkd: J. WILSON	Date: 03/10/2018		
Appd: J. WILSON	Date: 03/10/2018		
Scale:		on A4	



Drawing No. <b>WD6-0800-907</b>	Sheet <b>7</b> of <b>8</b>	Revision <b>1</b>
---------------------------------	----------------------------	-------------------



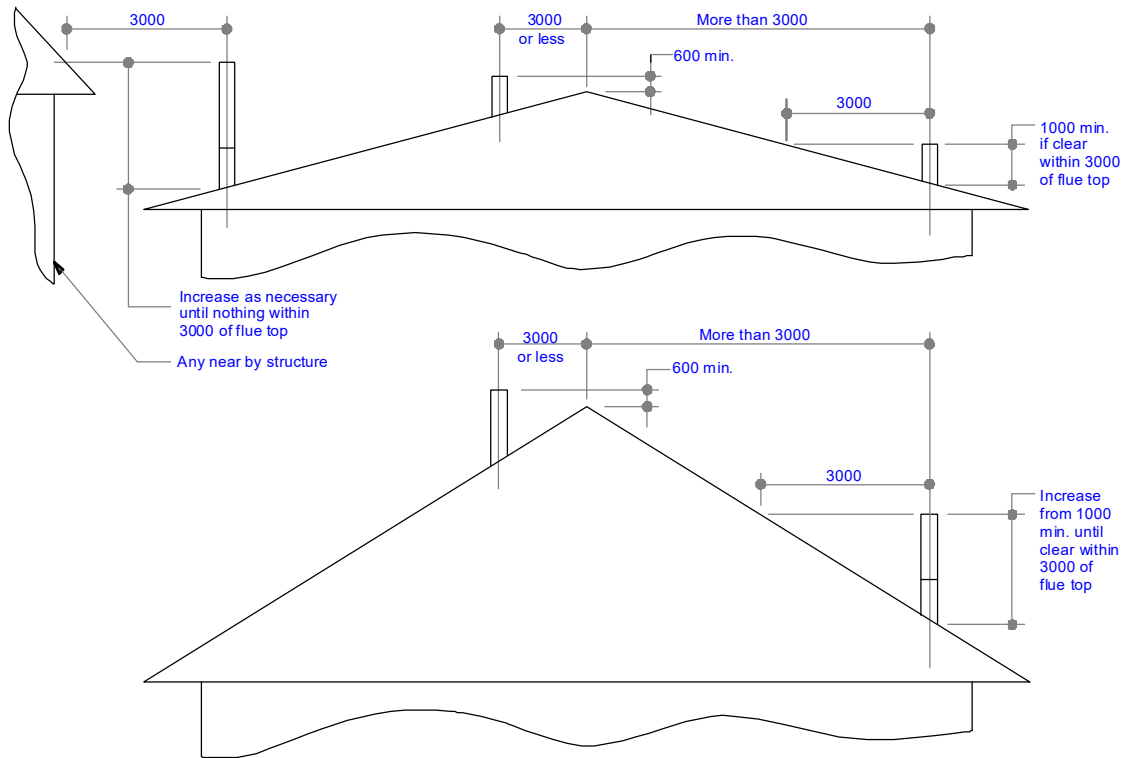

**Minimum Height of Flue System Exit**  
Or as per AS/NZS 2918:2001

COPYRIGHT ©  
 THIS DRAWING IS THE PROPERTY  
 OF **The Fire Dept.**

Client: THE FIRE DEPT.

Product: WD6-0800

Title: FLUE EXIT CLEARANCES

Drawn: J.SCHOEMAN

Date: 03/10/2018

Chkd: J. WILSON

Date: 03/10/2018

Appd: J. WILSON

Date: 03/10/2018

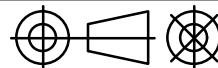

Scale: on A4



Drawing No. **WD6-0800-908**

Sheet 8 of 8

Revision **1**