



GD8 Exposed Burner

Installation Guide

Operating Instructions

Warranty

GD8 EB Installation Guide, Operating Instructions & Warranty

IMPORTANT!

This gas appliance must be installed to **AS/NZS 5601.1:2013** by a qualified person and in accordance with these instructions. Failure to install the appliance correctly will void your warranty and may cause a fire. This appliance should not be modified under any circumstances.

Under no circumstances should any combustibles such as paper, wood or coal be used in this appliance.

It is recommended that you have this appliance serviced annually by a qualified technician.

Warranty repairs must be carried out by a 'The Fire Dept.' authorised technician.

This appliance must ALWAYS terminate/flue outdoors.

Young children, elderly or infirm should be supervised to ensure that they are careful with the appliance.

Clothing and other flammable materials should never be placed near the appliance.

Please note that parts (near the flame) of this appliance, particularly the steel surrounding, all panels to the face or around the front, become extremely hot during operation and can result in serious injury and burns if touched. It is therefore recommended that a fireguard complying with BS 8423:2002 is used in the presence of young children, the elderly or infirm.

NOTE: This GD8 EB appliance is fitted with an Oxyprotector (Oxygen depletion) pilot. Under NO circumstances should this pilot be replaced or removed.

The GD8 EB installation process consists of 8 steps	Page
Step 1: Ensure all components are correct and undamaged.	3
Step 2: Install plinth (if required).	3
Step 3: Install appliance into cavity	3
Exposed burner removal process	4
Exposed burner installation process	5
Firebox lining removal process	6
Step 4: Install flue and connect to appliance	10
Step 5: Connect and test electrical supply	12
Step 6: Connect gas supply and commission	14
Step 7: Lay the firebed	15
Step 8: Show owner how to operate appliance	18
Operating Instructions.	19
Troubleshooting	19
Warranty	20

Information in this installation guide may be subject to change without notice. Please ensure that you have the current version before beginning installation.

If you have any queries, please contact 'The Fire Dept.' on 0800 888 550

Step 1: Unpack and ensure all components are correct and undamaged

- Firebox
- Box of firebed mediums
- Flue kit

Step 2: Install plinth (if required)

- If the appliance is to sit on a plinth, ensure it is capable of supporting a 350kg load.
- There is no clearance requirement for the base of the appliance. It may safely sit directly upon combustible (eg. timber) and non-combustible (eg. concrete) materials.

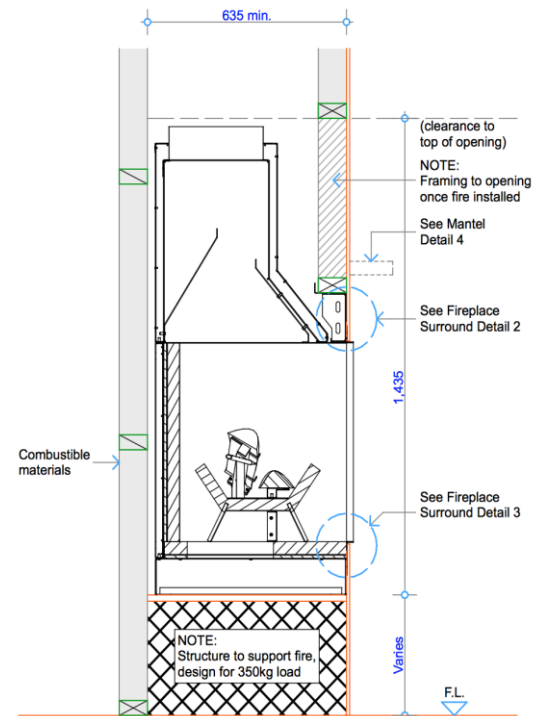

Step 3: Install appliance into cavity

- Before installation, confirm all minimum clearances from the outside surfaces of the appliance to the surrounding enclosure are no closer than 25mm from combustible materials and 5mm from non-combustible materials.
- The exception to these minimum clearances is the base, the front surround and lintel panels of the appliance. The base can safely sit directly upon combustible (e.g. timber) and non-combustible (e.g. concrete) materials and the front surround and lintel panels can be placed hard against non-combustible materials. Please refer to the appropriate appliance specifications for all correct clearance requirements.

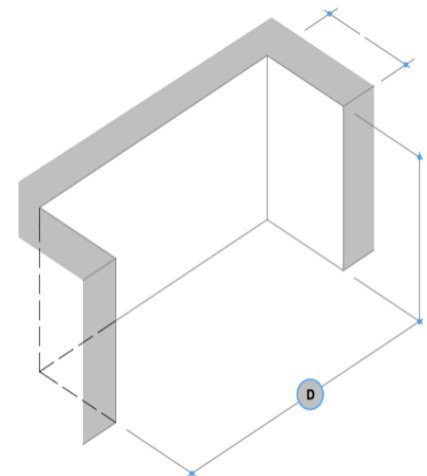

Fire Installation - Trim Sizes

- If a gas supply pipe has already been run to the cavity, ensure 1000mm of 3/8 soft copper tube is available at the lower centre of the cavity, as this is where the copper tube with the gas supply enters the appliance.
- If an electrical supply cable has already been run to the cavity (must be a minimum of 1.0mm 4 core cable), ensure that the cable reaches the centre of the cavity, as this is where it will enter the appliance.
- In order to access the fixing slots in the base of the appliance, and the gas and electrical connections, it is necessary to first remove the exposed burner and base firebox lining.

Exposed Burner Removal Process

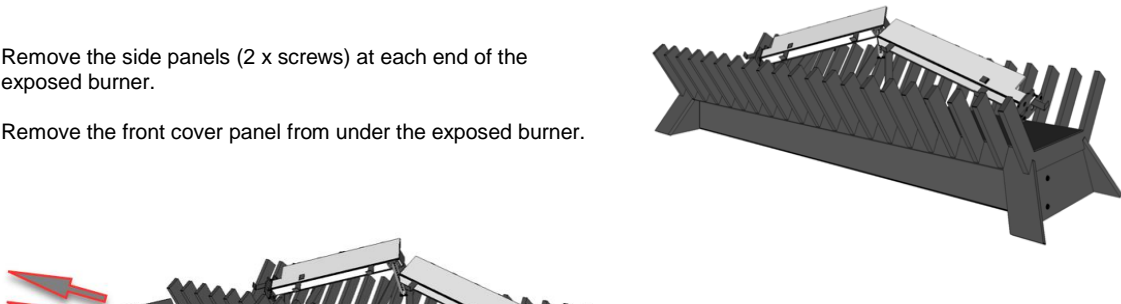
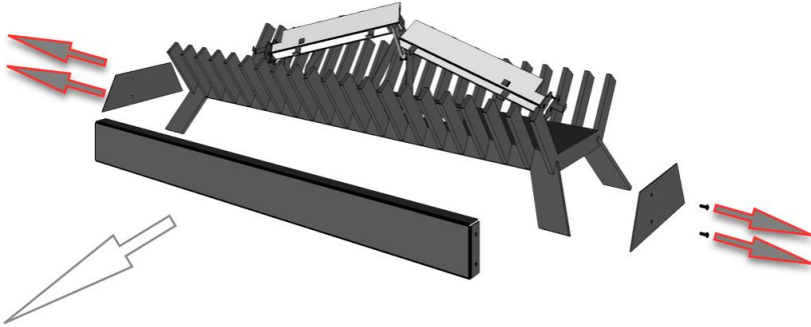
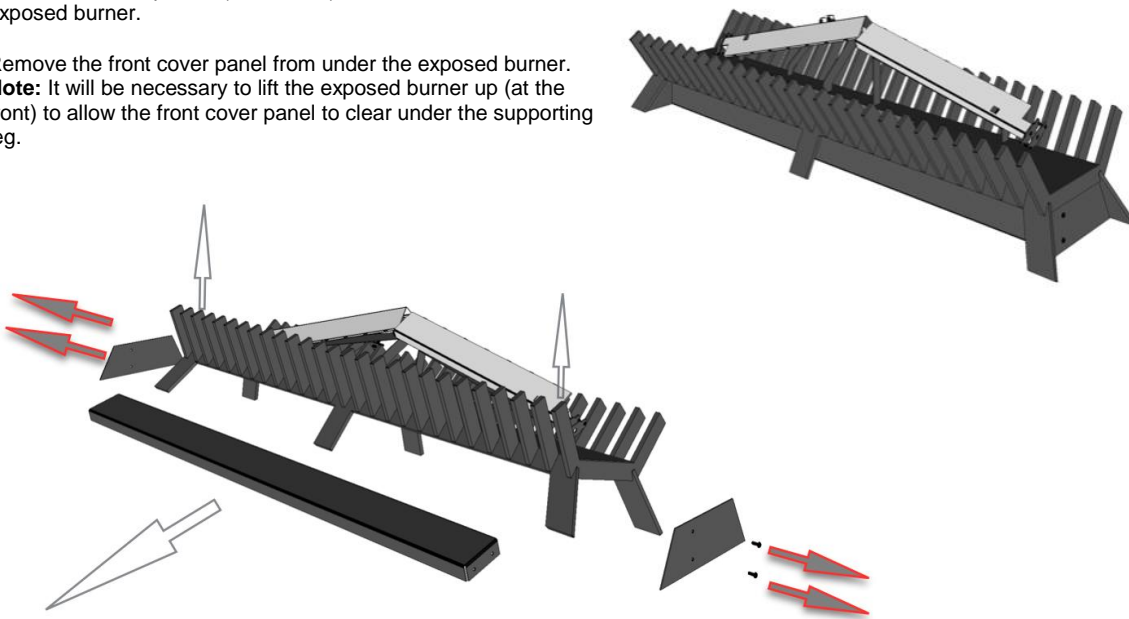
	LPG / Natural Gas
<p>GD8 EB Cover Panels</p>	
<p>GD8 EB 1200</p> <p>Input 55-65 MJ/h One gas injector on the front burner tube and two gas injectors on each of the two rear burner tubes.</p>	<ul style="list-style-type: none"> Remove the side panels (2 x screws) at each end of the exposed burner. Remove the front cover panel from under the exposed burner. 
<p>GD8 EB 1400</p> <p>Input 55-65 MJ/h One gas injector on the front burner tube and two gas injectors on each of the two rear burner tubes</p>	
<p>GD8 EB 1600</p> <p>Input 65-70 MJ/h One gas injector on the front burner tube and two gas injectors on each of the two rear burner tubes</p>	<ul style="list-style-type: none"> Remove the side panels (2 x screws) at each end of the exposed burner. Remove the front cover panel from under the exposed burner. Note: It will be necessary to lift the exposed burner up (at the front) to allow the front cover panel to clear under the supporting leg. 

Exposed Burner Installation Process

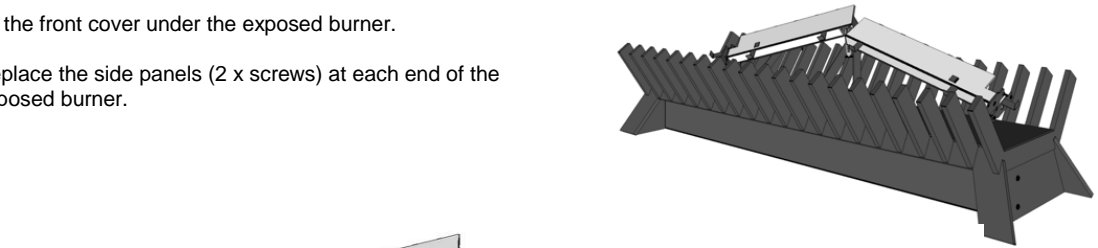
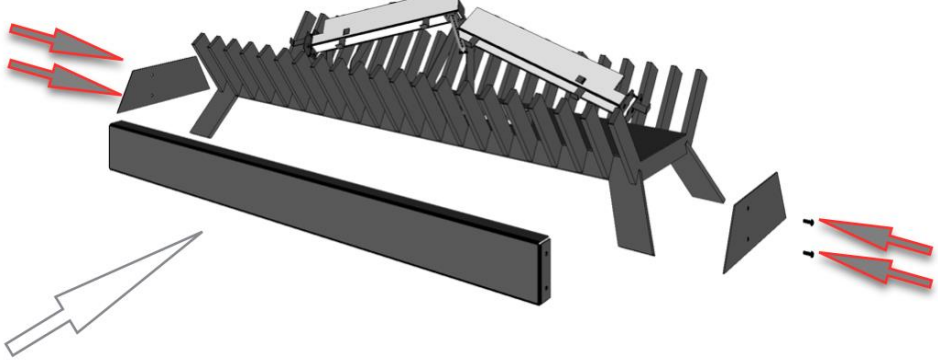
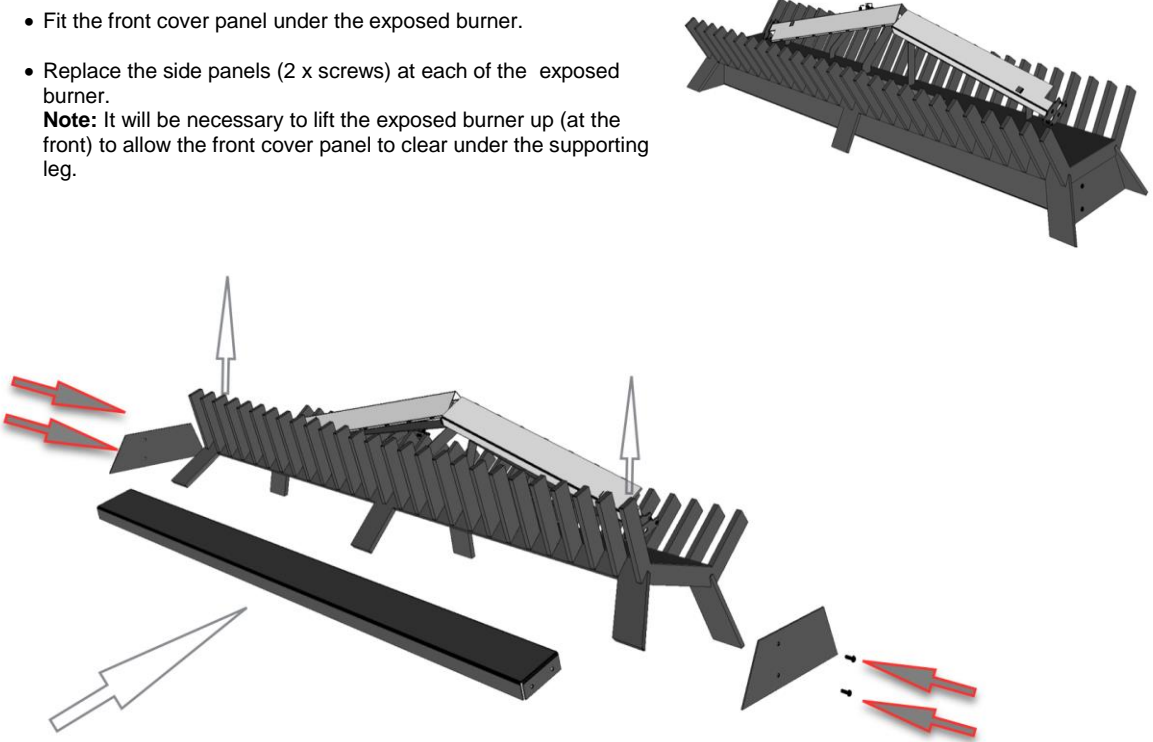
LPG / Natural Gas	
<p>GD8 EB 1200</p> <p>Input 55-65 MJ/h One gas injector on the front burner tube and two gas injectors on each of the two rear burner tubes.</p>	<ul style="list-style-type: none"> • Fit the front cover under the exposed burner. • Replace the side panels (2 x screws) at each end of the exposed burner. 
<p>GD8 EB 1400</p> <p>Input 55-65 MJ/h One gas injector on the front burner tube and two gas injectors on each of the two rear burner tubes.</p>	
<p>GD8 EB 1600</p> <p>Input 65-70 MJ/h One gas injector on the front burner tube and two gas injectors on each of the two rear burner tubes</p>	<ul style="list-style-type: none"> • Fit the front cover panel under the exposed burner. • Replace the side panels (2 x screws) at each of the exposed burner. Note: It will be necessary to lift the exposed burner up (at the front) to allow the front cover panel to clear under the supporting leg. 

Firebox Lining Removal Process

- In order to install the GD8 Exposed Burner, **the base firebox lining must be removed** to gain access to the base fixing brackets.
- **NOTE:** in some circumstances (eg. the need to reduce overall weight so the appliance can be lifted up stairs), it may be necessary to remove (then replace) all the firebox lining.

.....

- The GD8 has four fire box lining options: Fire bricks, Steel, Dark tile & Client-supplied.
- Particular care should be taken when removing and replacing the chosen Fire lining into the appliance. Failure to place the firebox lining correctly may result in the appliance performing inefficiently.

Fire Brick lining:

Herringbone - Hand cut fire bricks, 230mm x 25mm x 50mm.

Finish - Honed surface with grey grout.

Repair grout. To grout all joints and fill all shrink back cracks during appliance installation.



Steel lining:

Mild steel – 2mm.

Size – Cut and folded to suit appliance.

Finish – Matt black paint.

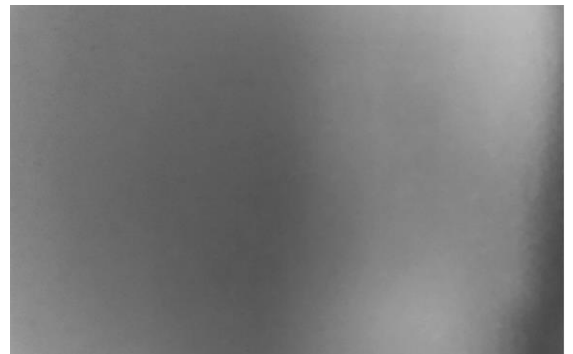

Dark tile lining:

Black slate – 9mm.

Size – 600mm x 600mm cut to suit.

Finish – Dark slate.



Client-supplied lining: Requirements

Non-combustible and heat-resistant.

Size – maximum thickness 50mm

Size – Minimum height for tiles 600mm

All measurements must be confirmed on site.

Finish – Robust and self-supporting.



Example of a client -suppled fire box lining

This GD8 EB appliance is supplied with the chosen firebox lining or ready for the client-supplied firebox lining.

Note: Take care when removing the top fixing bracket. The top of the firebox lining will fall forward with the bracket removed.

1. Remove the exposed burner by following the 'Exposed Burner Removal Process' in this guide.
2. Remove the top three lining fixing brackets. 5mm cap screws.
3. Allow the top of the lining to fall forward.
4. Carefully lift the lining up and out of the base channel.
5. Place the lining in a safe place.
6. Remove the base lining by carefully lifting the lining from the cavity at base from under the exposed burner.
7. To refit the lining simply reverse the removal process.
8. Install the exposed burner by following the 'Exposed Burner Installation Process' in this guide.

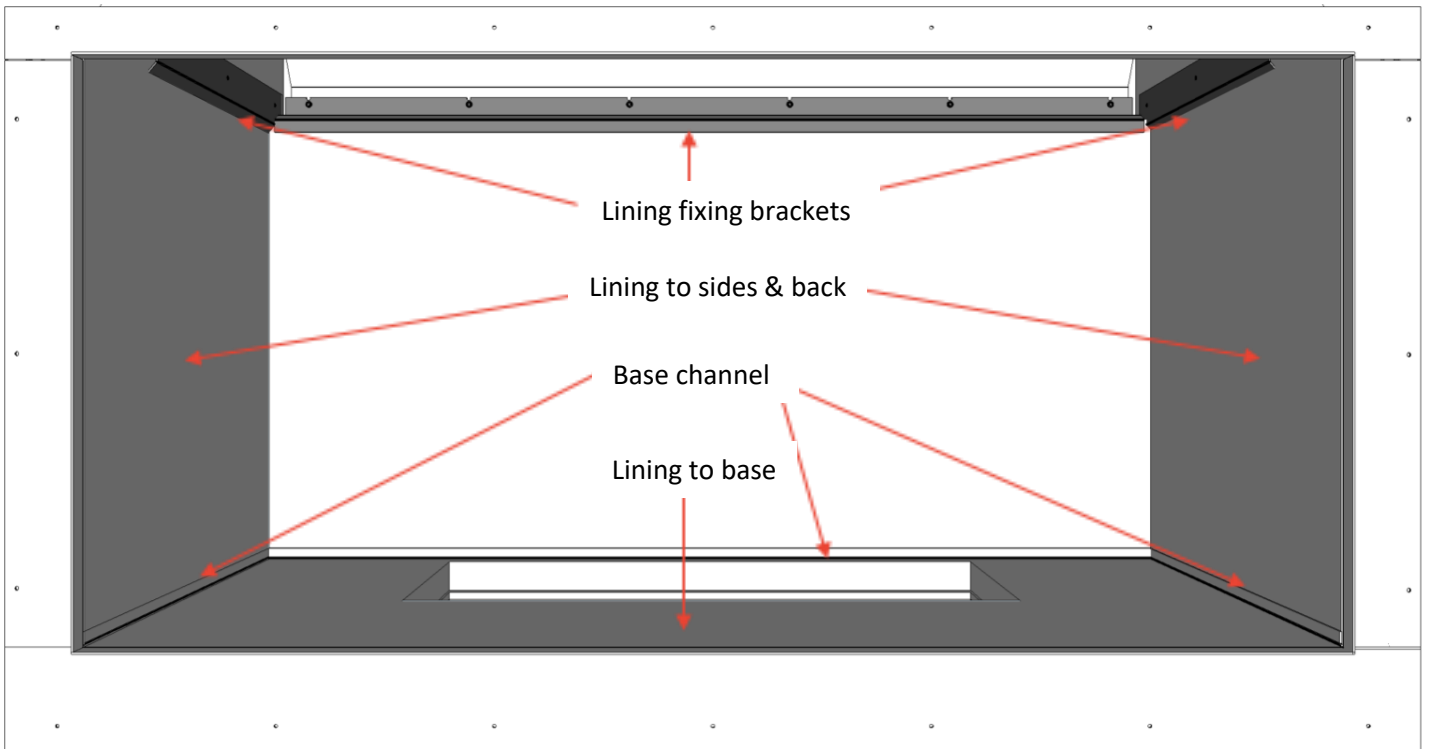

- Once the base firebox lining has been removed, slide the appliance into position and ensure that it complies with the minimum clearances required (25mm for combustibles, 5mm for non-combustibles) to the fire box inner panels and 5mm surrounding enclosure. The exception to these minimum clearances is the base and the outer 2mm steel lintel panel of the fire, the base can safely sit directly upon combustible (e.g. timber) and non-combustible (e.g. concrete) materials. Ensure the framing is capable of supporting a 350kg load.
- In order to provide maximum positioning flexibility, the base of the appliance has two fixing brackets with two 30mm long slots in each.
- The two fixing brackets will clamp the appliance into position. Locate the fixing brackets and mark out and drill fixing holes through the 30mm slots in the fixing brackets. Ensure holes are drilled in the centre of the slots to allow maximum positioning flexibility. Clear out any debris from drilling.

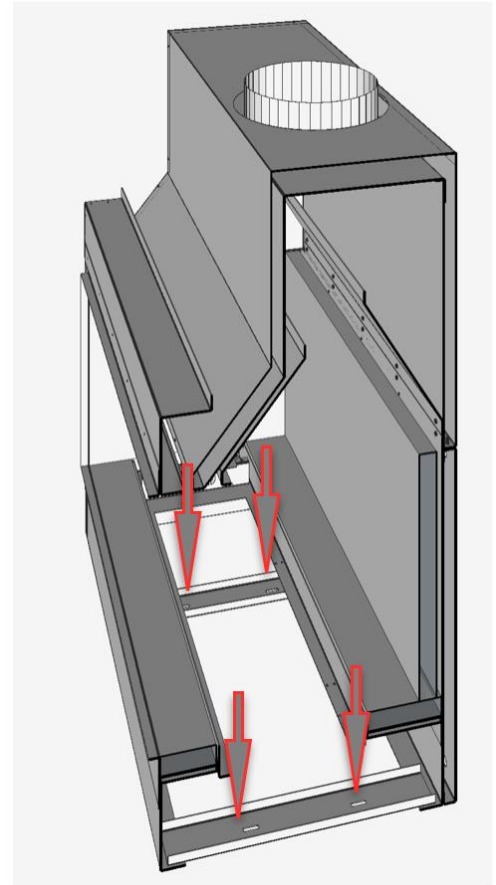
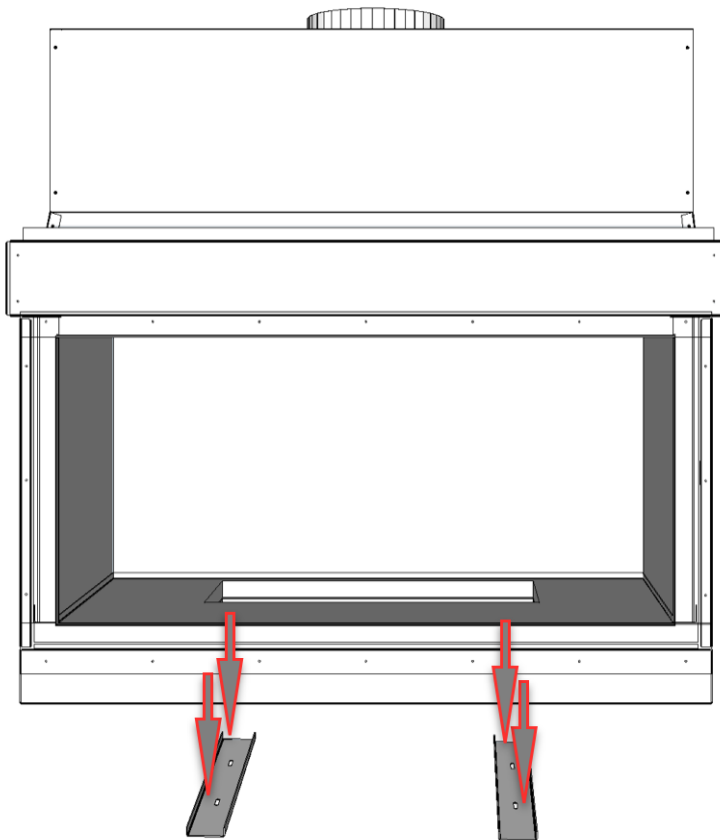

- Ensure the appliance is level and pack up corners to suit where necessary. Fix bolts/screws into floor. Check and ensure unit is level.
- Once the appliance is fixed into position the outer 2mm steel lintel panel can be bolt / screw fixed to the cavity.
- In order to provide maximum positioning flexibility, the outer 2mm steel lintel panel has two side fixing brackets with two 30mm long slots in each.

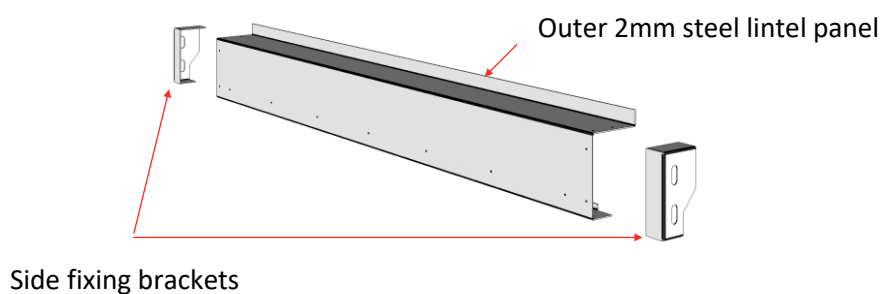

- The two side fixing brackets will hold the outer 2mm steel lintel panel in position. Locate the fixing brackets (see correct specifications or general assembly drawings) and mark out and drill fixing holes through the 30mm slots in the Side fixing brackets. Ensure holes are drilled in the centre of the slots to allow maximum positioning flexibility. Clear out any debris from drilling.

- Ensure the Side fixing brackets are level. Fix bolts/screws to the side fixing brackets to each side of the cavity.

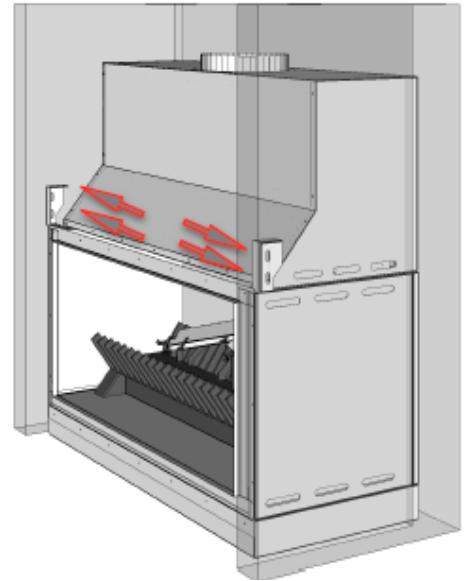

- The outer 2mm steel lintel panel will fit snugly over and fix to the side fixing brackets.

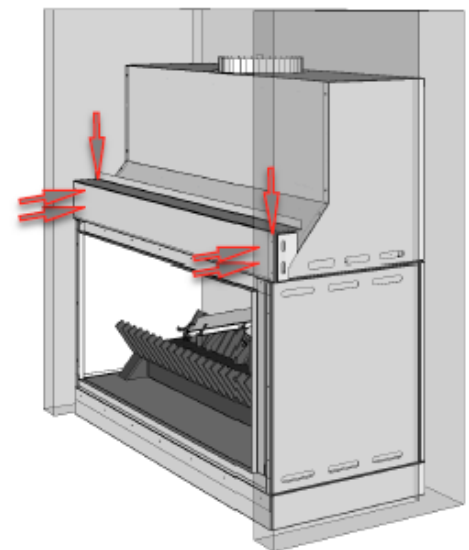

- Replace the base firebox lining.
- Replace the front panel and the exposed burner by following the '**Exposed Burner Installation Process**' in this guide.

Step 4: Install flue and connect to appliance

- Flue installation must meet the requirements of AS/NZS 5601.1:2013 and comply with all local council requirements and be installed and certified by a suitably qualified person.
- Refer to appropriate 'The Fire Dept' product specifications for specific minimum requirements. Only follow the '**Wall cowl assembly details**' (below) if the flue is to be terminated through a wall.
- A 25mm clearance from combustible materials, 75mm clearance from wiring and plastic pipes and a minimum of 5mm from non-combustible materials is required when installing a flue system for any appliance supplied by 'The Fire Dept.'.
- The flue installation requires a restriction free cavity from the top of the firebox (flue spigot) to the outside atmosphere.
- Air flow must be unobstructed from the firebox to the inner flue and from the heat shield to outer casing allowing air to circulate from the firebox to the flue casings to the atmosphere.

In-Line Fan assembly details

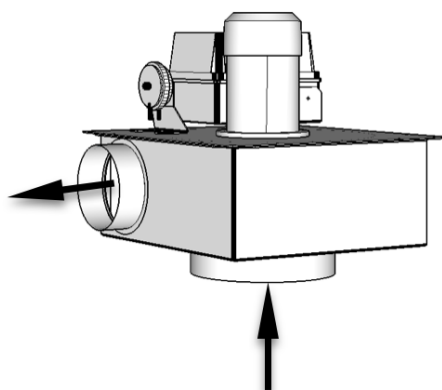

Step 1: Connect the flue and outer casing to the firebox

1. Make sure the In-line fan has adequate access for future maintenance.
2. Run the flue from the appliance to the location of the In-line fan.
3. Run the outer casing from the appliance to finish 50mm shorter than the flue.



Step 2: Connect the in-line fan to the flue and outer casing

1. Fit the casing slip over the outer casing.
2. Fit the flue over the inlet spigot to the In-line fan.
3. Fix the flue to the inlet spigot at the in-line fan.

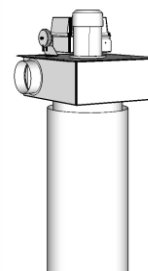

Step 3 Complete the flue installation

1. Finish the casing with a 50mm gap to the in-line fan.
2. Complete the flue installation .Refer to appropriate' product specification for fixing details and specific minimum requirements.

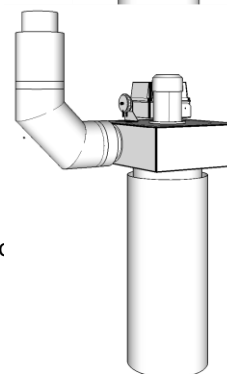

Wall cowl assembly details

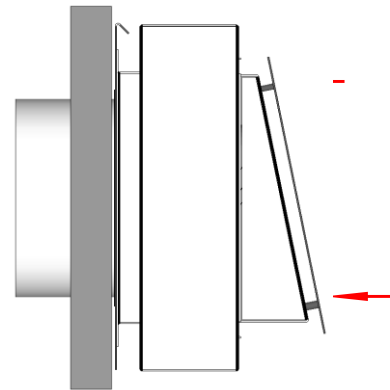
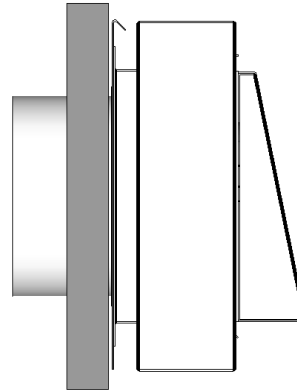
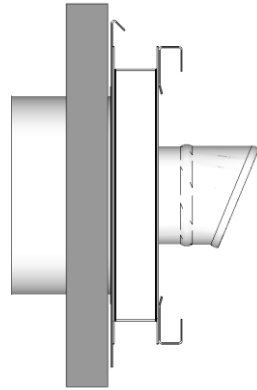
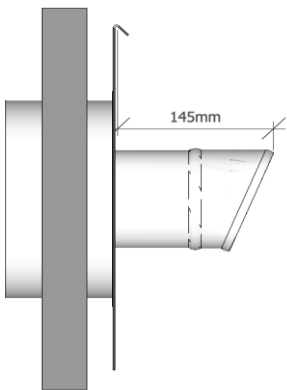
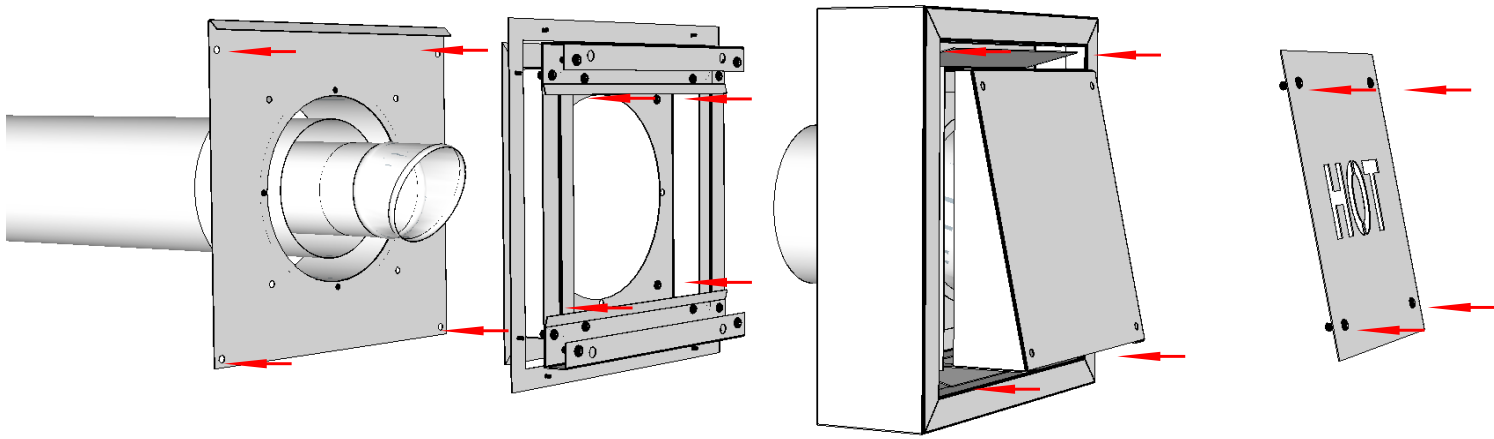

Step 1: Fix back panel to wall

1. Back panel must be flashed in accordance with NZBC.
2. Outer flue casing to finish flush with front of back panel.
3. Flue to finish 145mm out from back panel.

Step 2: Fix cowl support to back panel

1. Cowl support is fixed to back panel with 4 x 5mm cap screws
2. Seal between cowl support and back panel with heat proof sealer.

Step 3: Fix cowl to cowl support

1. Cowl is fixed to back panel with 4 x 5mm cap screws
2. The outer casing spigot (attached to the cowl) will slide into the outer flue casing.

Step 4: Fix HOT panel to the cowl.

1. Hot panel is fixed to back panel with 4 x 5mm cap screws

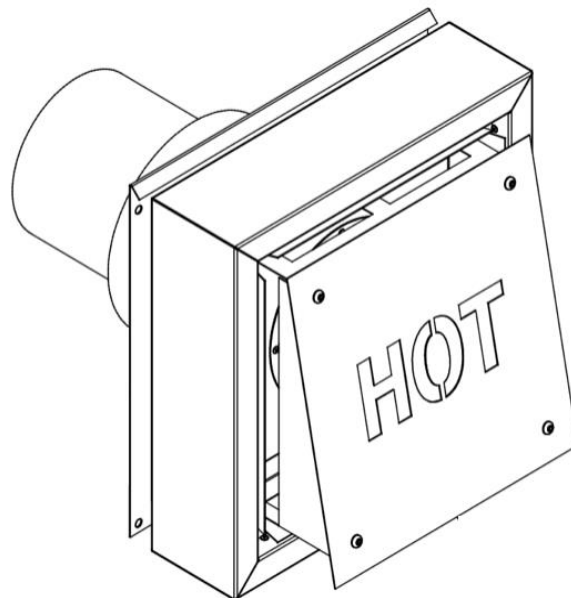

Step 5: Connect and test electrical supply

- All electrical connections must meet the requirements of AS/NZS 3000 standards and be installed and certified by a suitably qualified person.
- In order to access the electricals, it is necessary to first remove the front cover panel. Follow the front cover removal process on the '**Exposed Burner Removal** Process' of this guide.
- If the exposed burner needs to be removed. Follow the exposed burner removal process in the '**Exposed Burner Removal Process**' of this guide.

Note: The exposed burner can be lifted and supported at a height to give extra working room if required.



- With the front panel removed the electrical connections between the appliance and the switch can be seen, use 4 core (minimum 1mm) cable.
- Following these connection details, using the 4 core cable that has been run at site, connect the switch to the appliance.
- **IMPORTANT: Before testing, ensure the gas valve is turned off.**



- Test electrical functions by switching the bottom High/Low switch to LOW, then switch the appliance ON using the top On/ Off switch.
- After approximately five seconds, the pilot will spark. Because the gas supply is turned off, the pilot will spark for approximately five seconds then automatically switch off.
- **NOTE:** GD8 models have both LOW and HIGH settings.
- Switch to HIGH setting. Ensure that a red light appears on the electrical connections block.
- Switch the appliance off. Electrical testing is complete.
- Replace the front panel and the exposed burner by following the '**Exposed Burner Installation Process**' in this guide.

ITEM	QTY	DESCRIPTION
1	1	SIT 843 Sigma
2	1	Electrical controller
3	1	Air Pressure Switch
4	1	Larger combustion fan unit assembly
5	1	SIT - Oxyplot

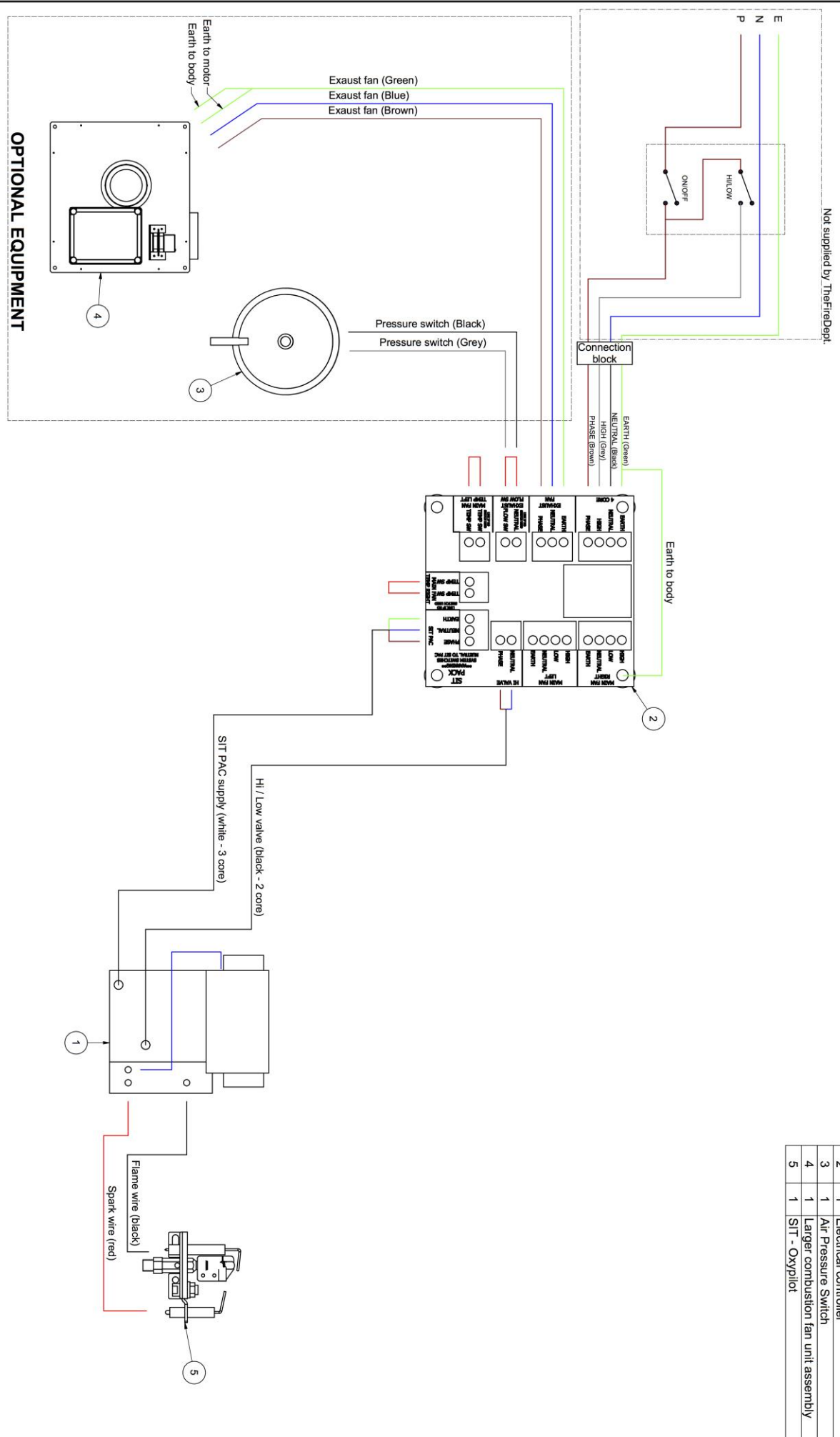

OPTIONAL EQUIPMENT

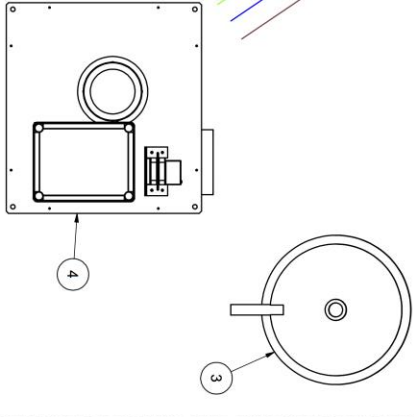

REV. No.	DATE	REV. BY	REVISIONS	CHKD. BY	DATE	APPD. BY
0	2018/03/05	J.S.	ISSUED FOR MANUFACTURE			
1	2018/07/29	J.S.	DIAGRAM LINE COLOURS UPDATED			

DRAWING NO.		REFERENCE DRAWINGS	
GD8-1200-451			

Client: THE FIRE DEPT - STANDARD SERIES	
Project: GD8	
Title: Electrical line diagram	Date: 8/03/2018
Drawn: J.SCHOEMAN	Date:
Chkd:	Date:
Appd:	Date:
Scale: on A2	

Sheet 1 of 1	Revision 1
--------------	------------

COPYRIGHT
 THIS DRAWING IS THE PROPERTY
 OF **The Fire Dept.**
 AND IS CONFIDENTIAL AND IS
 SUPPLIED ON THE EXPRESS
 UNDERSTANDING THAT IT IS
 NOT TO BE REPRODUCED,
 COPIED OR COMMUNICATED TO
 ANY OTHER PERSON WITHOUT
 THE WRITTEN PERMISSION OF
 THE PROPRIETORS.

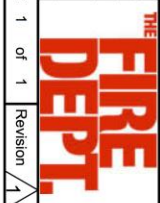

GD8-1200-451.rvt

Step 6: Connect gas supply and commission

- Gas installation, connection and commissioning must meet the requirements of AS/NZS 5601.1:2013 and be installed and certified by a suitably qualified person.
- In order to access the gas supply and testing area, it is necessary to first remove the front cover panel. Follow the front cover removal process on the '**Exposed Burner Removal Process**' of this guide.
- If the exposed burner needs to be removed. Follow the exposed burner removal process in the '**Exposed Burner Removal Process**' of this guide.

Note: The exposed burner can be lifted and supported at a height to give extra working room if required.



- Connect 3/8 soft copper pipe to main valve.



- In the unlikely event that the rating plate is not attached, **Do Not** commission the appliance and contact 'The Fire Dept.' immediately.
- Replace the exposed burner (if removed) by following the '**Exposed Burner Installation Process**' in this guide.
- Switch the appliance on.
- **Note:** due to lack of firebed, it may be necessary to manually light burners.



- Leak test all joints.
- Test/adjust high first and then the low pressures against rating plate specifications.
- Switch the appliance off.
- Lay firebed in accordance with instructions in Step 7 of this guide.
- Send gas certificate to the appropriate person.

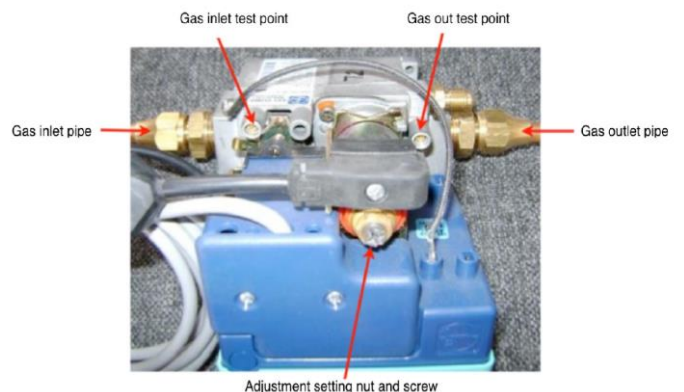

Step 7: Lay the firebed

- The GD8 Exposed Burner has two firebed mediums: white rocks and logs.
- Particular care should be taken when placing the firebed mediums into the burners. Failure to place the medium correctly may result in the appliance performing inefficiently.
- Open the firebed cardboard box and identify firebox mediums.

GD8 EB 1200 & 1400 has two firebed mediums

Logs – large and small

White rocks – large and small



GD8 EB 1600 has two firebed mediums:

Logs – large and small

White rocks – large and small



How to lay the Firebed – GD8 EB 1200 and 1400



Step 1



Step 2



Step 3



Step 4



Step 5



Step 6



Step 7



Step 8



Step 9



- Switch the appliance on at 'HIGH' setting to check how flame looks. The flame will take 10-20 seconds to light fully.
- **IMPORTANT:** the flame effect should look natural and non-uniform, running the entire length of the burner.
- Common flame effect issues are:
 - Flame burning under logs.
 - Missing flames along length of burner.
- Both these issues can be resolved by switching the appliance off and slightly repositioning rocks and logs at the problem areas.
- Repeat this switching on/off and repositioning until a natural and non-uniform flame effect is achieved.
- Once a natural and non-uniform flame effect is achieved, switch the appliance to 'LOW' setting and ensure the flame effect, although smaller, still looks good.
- Switch the appliance off.

How to lay the Firebed – GD8 EB 1600



Step 1



Step 2



Step 3



Step 4



Step 5



Step 6



Step 7



Step 8



Step 9



- Switch the appliance on at 'HIGH' setting to check how flame looks. The flame will take 10-20 seconds to light fully.
- **IMPORTANT:** the flame effect should look natural and non-uniform, running the entire length of the burner.
- Common flame effect issues are:
 - Flame burning under logs.
 - Missing flames along length of burner.
- Both these issues can be resolved by switching the appliance off and slightly repositioning rocks and logs at the problem areas.
- Repeat this switching on/off and repositioning until a natural and non-uniform flame effect is achieved.
- Once a natural and non-uniform flame effect is achieved, switch the appliance to 'LOW' setting and ensure the flame effect, although smaller, still looks good.
- Switch the appliance off.

Step 8: Show owner how to operate appliance

- Following the GD8 Exposed Burner Operating Instructions on the next page, show the owner how to switch the appliance on and off, and how to switch between high and low settings.
- If the owner is not available, leave this manual by the appliance.

NOTES:

GD8 EB OPERATING INSTRUCTIONS

This GD8 appliance has been designed to be simple to use. It is controlled by a wall switch, which must be installed by a qualified electrician.

To start appliance:

- Press the on/off switch to the ON position.
- Press the high/low switch to the HIGH position.
- The electronic solenoid pack will start to click.
- Gas will then be released and ignited at the pilot valve.
- The safety sensor will allow the main burner pipe to ignite and flames will appear. The whole process will take between 10-20 seconds.
- Once the flame appears, it can be turned down to the low setting by pressing the high/low switch to LOW.

To shut down appliance:

- Press the on/off switch to the OFF position.
- The gas will automatically be shut off to the pilot and the burner. The flame will then extinguish.

TROUBLESHOOTING

Problem	Probable Cause	Action
Appliance shuts down after continuous running.	Low oxygen supply to the appliance	1. Do not attempt to restart the fire.  2. Open all doors and windows. 3. Call gas-fitter.
Appliance doesn't start	1. No gas supply 2. No power supply 3. Low or poor pilot flame 4. Signal from flame rectifier interrupted 5. Signal to sparker electrode interrupted 6. Incorrect sparker electrode gap	1. Check gas supply 2. Check power supply 3. Check flame size and pressure 4. Check flame rectifier and wire to sit pack 5. Check sparker gap and wire to sit pack 6. Check sparker electrode gap is 3mm
Appliance shuts down	1. Low gas supply 2. Low or poor pilot flame 3. Signal to flame rectifier interrupted	1. Check gas supply 2. Check flame size and pilot flame pressure 3. Check flame rectifier and wire to sit pack
Flame in not running the full length of the burner	The firebed is not aligned to the burner	Re-lay the firebed to the specific model specifications detailed earlier in this guide
Flame is yellow and sooty	1. Primary aeration ports have a blockage (LPG models only) 2. The firebed is not aligned to the burner	1. Check primary aeration ports for blockage and clear if required (LPG models only) 2. Re-lay the firebed to the specific model specifications detailed earlier in this guide
No flame at the pilot	Primary aeration ports have a blockage	Check primary aeration ports for blockage and clear if required
(For models with an in-line flue fan) If the in-line fan is running and the appliance doesn't start or shuts down	Low air flow supply from the appliance	1. See 'Appliance doesn't start' above. 2. See 'Appliance shuts down' above. 3. Call gas-fitter.

PRODUCT WARRANTY

IMPORTANT: Evidence of original purchase is required for warranty service.

WARRANTOR: 'The Fire Dept.' (Landscape Elements Ltd)
85 Newton Road
Mount Maunganui
PO Box 10275, Bayfair, Mount Maunganui

ELEMENT OF WARRANTY

'The Fire Dept.' warrants to the original retail owner for the duration of this warranty, its fireboxes, gas burner tray, lighters, (herein after referred to as the Product) to be free from defects in materials and craftsmanship with only the limitations or exclusions set out below.

WARRANTY

This warranty will be deemed invalid if the Product is;

- (A) Installed by someone other than an authorised Fire Dept agent.
- (B) Not operated appropriately or "over-fired" in a manner resulting in the firebox operating excessively hot.
- (C) Not serviced and maintained by a certified gas fitter every 12 months.
- (D) Damaged by accident, neglect or misuse,
- (E) Repaired by someone other than an authorised Fire Dept repair agent for a defect or malfunction covered by this warranty.
- (F) Modified, altered or used as part of any conversion kits, subassemblies, or any configurations not sold by 'The Fire Dept.'.
- (G) The product contains fire bricks and has not been subjected to the recommended first start-up and run-in procedure.
- (H) Used in conjunction with any equipment or parts or as part of a system not manufactured or supplied by 'The Fire Dept.'.
- (I) External powder-coating within 200m of the high tide mark and not lightly washed with warm soapy water every three months.

Indoor appliances (Gas & Wood)

'The Fire Dept.' warrants the mild steel firebox, galvanised steel outer skin and RHS Duragal steel support frame against defective materials and workmanship which would render it unfit for normal domestic use, from the date of purchase by the original consumer, for a period of 5 (five) years. Beyond normal heat-induced staining, tarnishing and mild warping, if a firebox, outer skin or support frame defect occurs, contact 'The Fire Dept.' and the defect will be repaired or replaced at our discretion with all costs covered.

'The Fire Dept.' warrants the SIT Pack (Gas regulator and controller) against defective materials and workmanship which would render it unfit for normal domestic use, from the date of purchase by the original consumer, for a period of 2 (two) years.

Components including fire medium, fans, tiles, glass and glass trim are warranted for a period of 2 (two) years from the date of original purchase, against defective materials and workmanship.

Outdoor appliances (Gas & Wood)

'The Fire Dept.' warrants the Mild Steel firebox, galvanised steel outer skin and RHS Duragal Steel support frame against defective materials and workmanship which would render it unfit for normal domestic use, from the date of purchase by the original consumer, for a period of 2 (two) years. Beyond normal heat-induced staining, tarnishing and mild warping, If a firebox, outer skin or support frame defect occurs, contact 'The Fire Dept.' and the defect will be repaired or replaced at our discretion with all costs covered.

'The Fire Dept.' warrants the SIT Pack (Gas regulator and controller) against defective materials and workmanship which would render it unfit for normal domestic use, from the date of purchase by the original consumer, for a period of 2 (two) years.

Components including fire medium, fans, tiles, glass and glass trim are warranted for a period of 2 (two) years from the date of original purchase for domestic use, against defective materials and workmanship.

STATEMENT OF REMEDY

In the event that the Product does not conform to this warranty at any time while this warranty is in effect, the Warrantor, at its discretion, will repair the defect or replace the part and return it to you without charge for parts or service. This warranty does not provide for reimbursement or payment of incidental or consequential damages.

This warranty does not in any way affect your rights under the Consumers Guarantee Act (New Zealand).