



**WD5**  
**(Concrete and Timber Cavity)**

**Installation Guide**  
**Operating Instructions**  
**Warranty**

# WD5 (Concrete and Timber Cavity)

## Installation Guide, Operating Instructions & Warranty

### IMPORTANT!

This wood appliance must be installed to **AS/NZS 2918:2001** by a qualified person and in accordance with these instructions. Failure to install the appliance correctly will void your warranty and may cause a fire. This appliance should not be modified under any circumstances.

It is recommended that you have this appliance serviced annually by a qualified technician.

Warranty repairs must be carried out by a 'The Fire Dept.' authorised technician.

This appliance must ALWAYS terminate/flue outdoors.

Young children, elderly or infirm should be supervised to ensure that they are careful with the appliance.

Clothing and other flammable materials should never be placed near the appliance.

Please note that parts (near the flame) of this appliance become extremely hot during operation and can result in serious injury and burns if touched. It is therefore recommended that a fireguard complying with BS 8423:2002 is used in the presence of young children, the elderly or infirm.

During the installation of this appliance, it may be necessary to manually handle heavy components (greater than 25kg). It is the installer's responsibility to ensure appropriate manual-handling techniques are employed.

**This installation guide must be read in conjunction with the technical specification for this appliance. If an optional log ignitor is being used, it must be installed in accordance with the relevant log ignitor installation guide.**

### The WD5 (concrete and timber cavity) installation process consists of 8 steps

	Page
Step 1: Ensure all components are correct and undamaged	3
Step 2: Pre-installation checklist	4
Step 3: Fit gather	5
Step 4: Fit flue	7
Step 5: Fit front cover panel and front channel	8
Step 6: Install fire bricks	9
Step 7: Fit door and place grate into fire brick cavity	10
Step 8: Show owner how to operate appliance	11
Operating Instructions	12
Troubleshooting	12
Warranty	13

Information in this installation guide may be subject to change without notice.  
Please ensure you have the current version before beginning installation.

**If you have any queries, please contact 'The Fire Dept.' on 0800 888 550**



## **Step 1: Unpack and ensure all components are correct and undamaged**

- Gather.
- Grate.
- Flue kit.
- Fire bricks.
- Log ignitor (optional).
- WD5 technical specification (to be read in conjunction with this installation guide).
- Appropriate log Ignitor installation guide, if optional log ignitor is being used.

## Step 2: Pre-installation checklist

- Ensure cavity dimensions are correct – refer to technical specification.
- Ensure hearth dimensions are correct – refer to technical specifications.
- Plan flue path.
- If optional log ignitor is to be installed, check how gas and electricity supplies run to log ignitor.

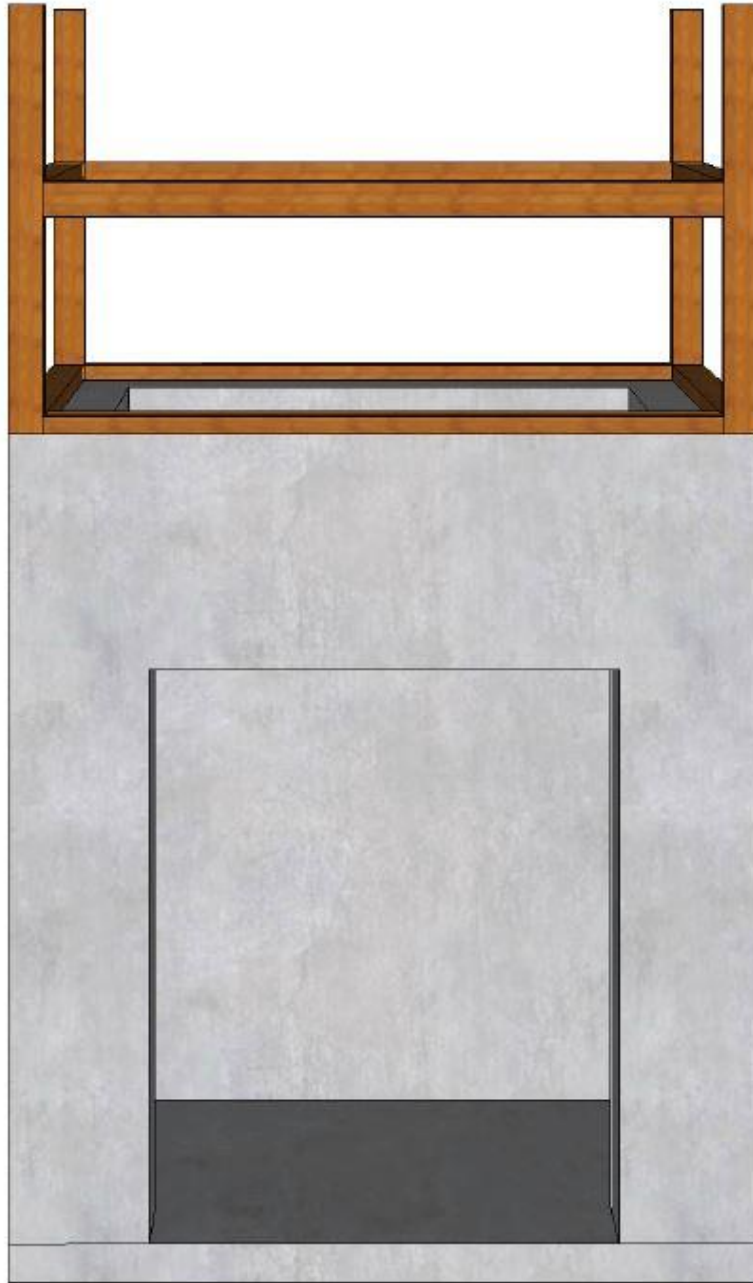

**The starting point: Concrete and timber frame with concrete hearth.**

## Step 3: Fit gather

**Important Safety Note:** It may be necessary to manually handle heavy components (greater than 25kg). It is the installer's responsibility to ensure appropriate manual-handling techniques are employed.

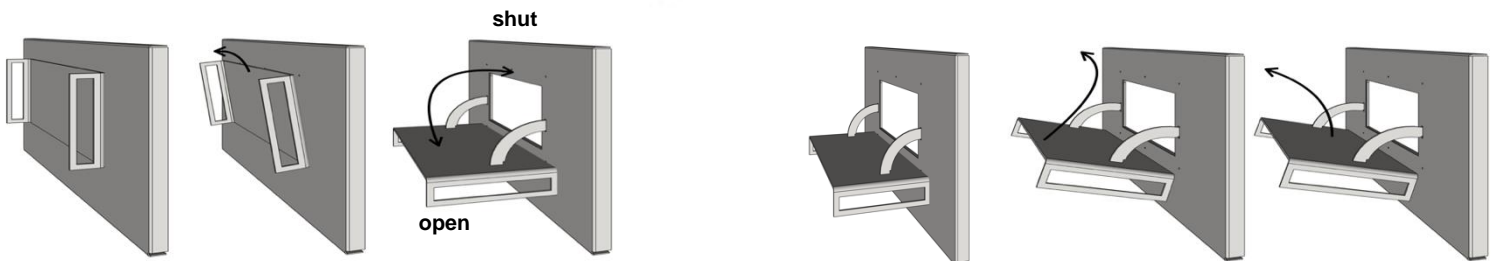
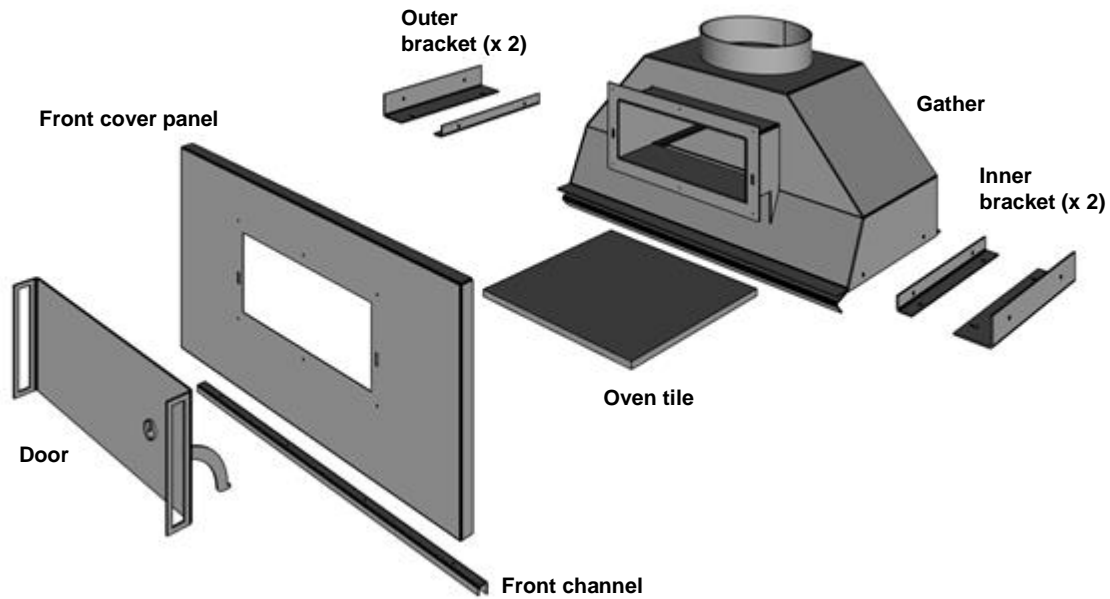

To open door, lift up and out in one movement.

To remove door, lift open door up and out in one movement.

**1. Remove door, front cover panel, front channel, inner brackets, outer brackets and oven tile.**

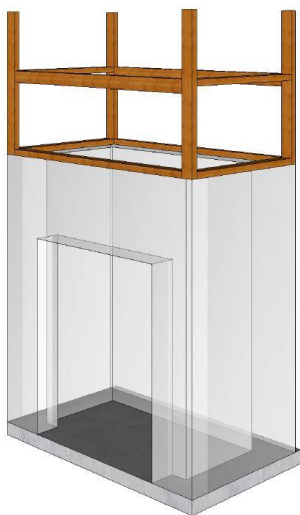

**2. Double-check chimney cavity dimensions are correct.**



**3. Drill and bolt the outer brackets (2 x 10mm concrete fixing bolts at each). Check technical specifications for outer bracket height and positions.**



**4. Loosely bolt inner brackets to the outer brackets.**

### Step 3: Fit gather (continued)

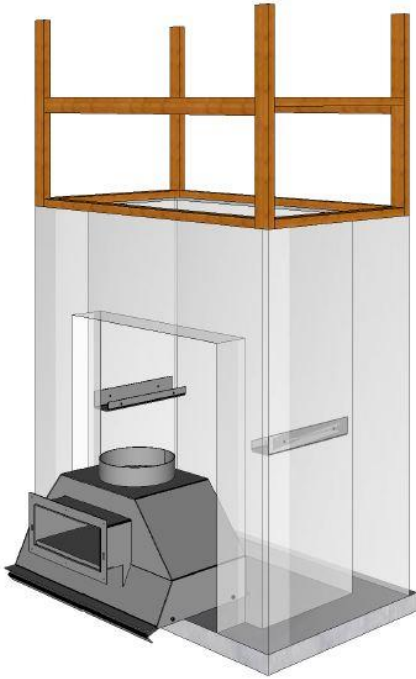

5. With a minimum of two people, position the gather in front of the cavity.

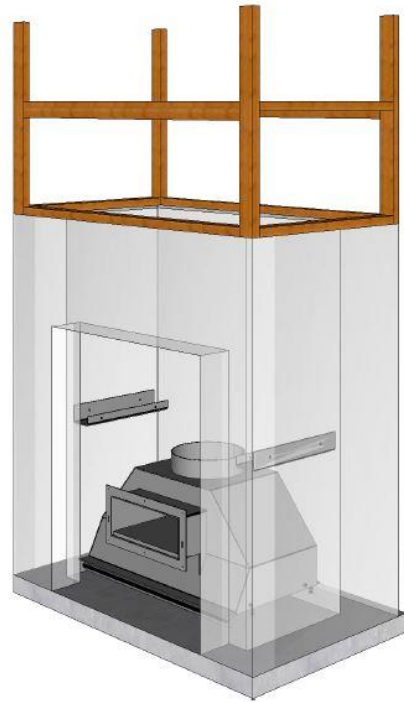

6. Push the gather into the cavity.

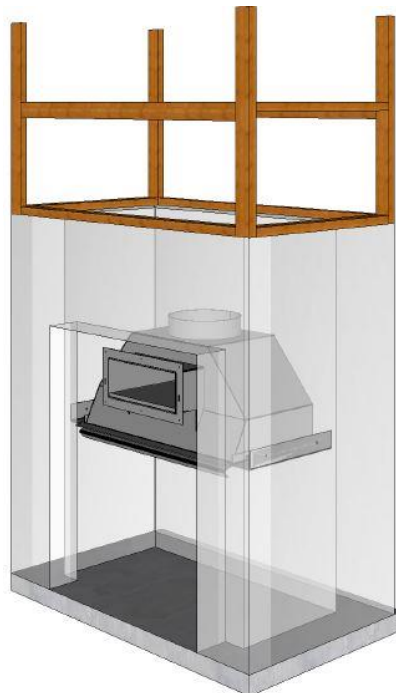

7. Using a block and tackle, lift the gather into position and bolt onto inner brackets (2 x 10mm bolts at each side). Tighten all bolts.

## Step 4: Fit flue

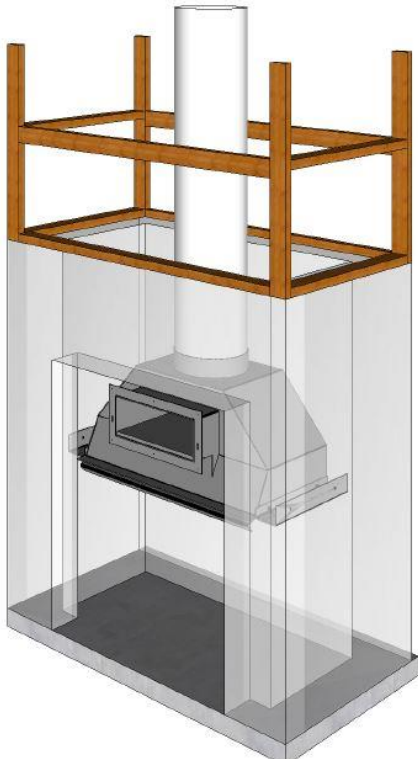

1. Run the first section of flue onto gather.

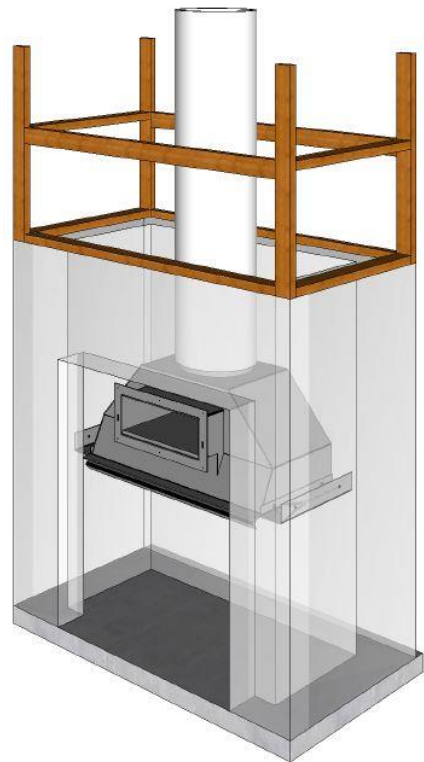

2. Run the first section of inner casing onto gather. Ensure 25mm gap between inner casing and gather.

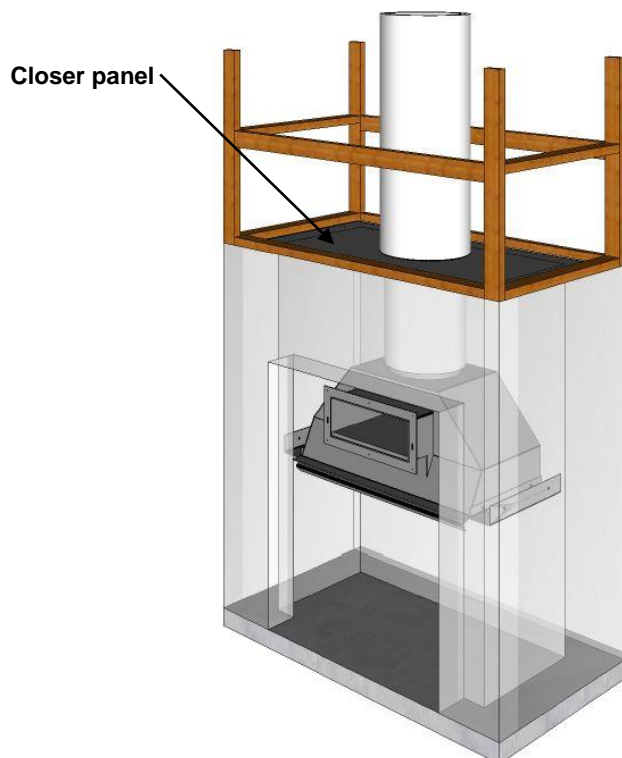

3. Fix the closer panel into position on top of the concrete chimney cavity. Then run the first section of the outer casing onto the closer panel.

4. Complete the rest of the flue installation.



## Step 5: Fit front cover panel and front channel

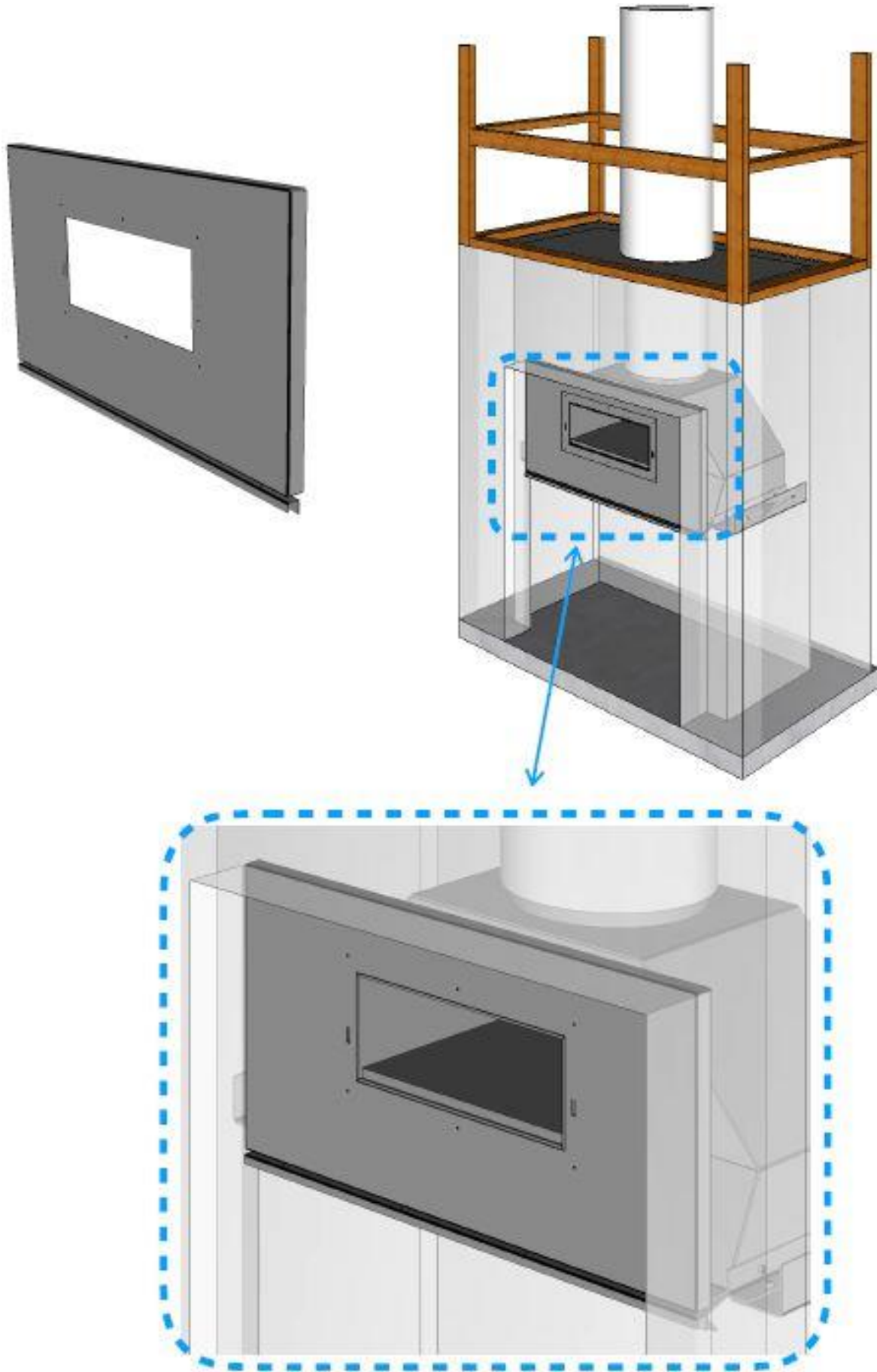

Fit front cover panel. 6 x 5mm cap screws.

Fit front channel below front panel. 5mm cap screws



## Step 6: Install fire bricks

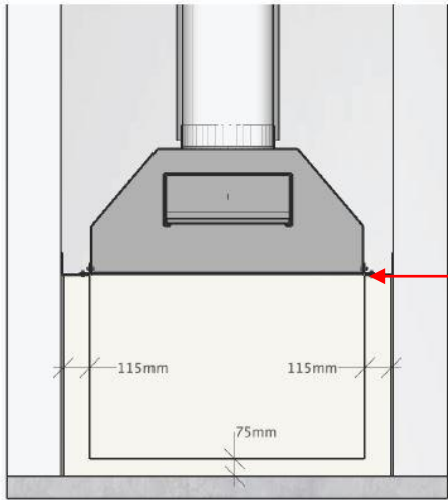

**IMPORTANT:** To avoid smoke entering the cavity, ensure the fire bricks are flush with the gather internal sides. Fill gap between fire-bricks and underside of gather with refractory cement.

Ensure an 80mm overlap between front face of fire bricks and back of gather.

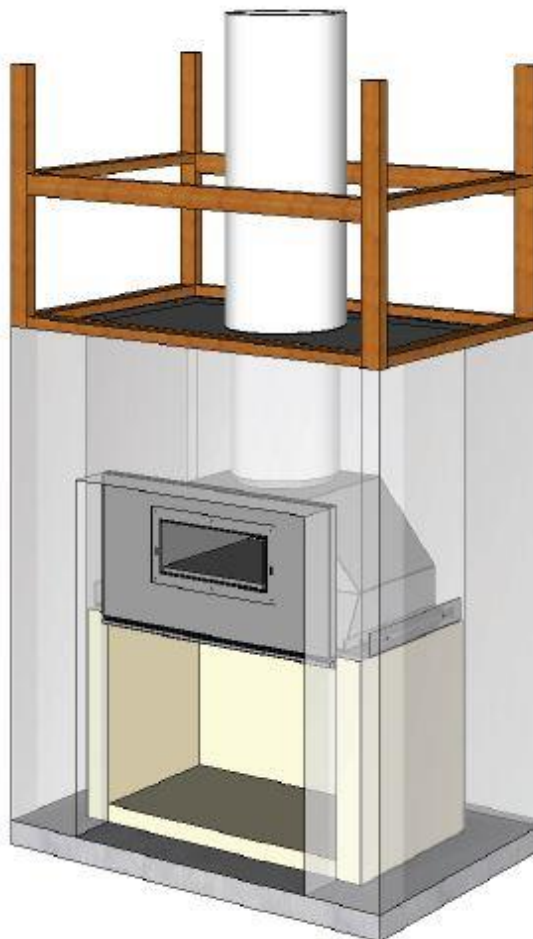
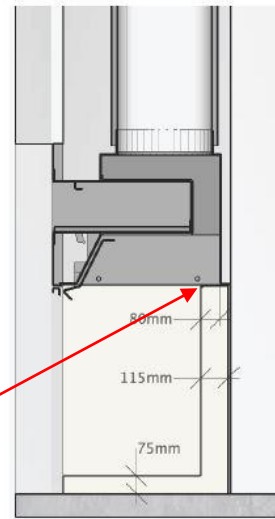

**Fire bricks complete.**

## Step 7: Fit door and place grate into fire brick cavity

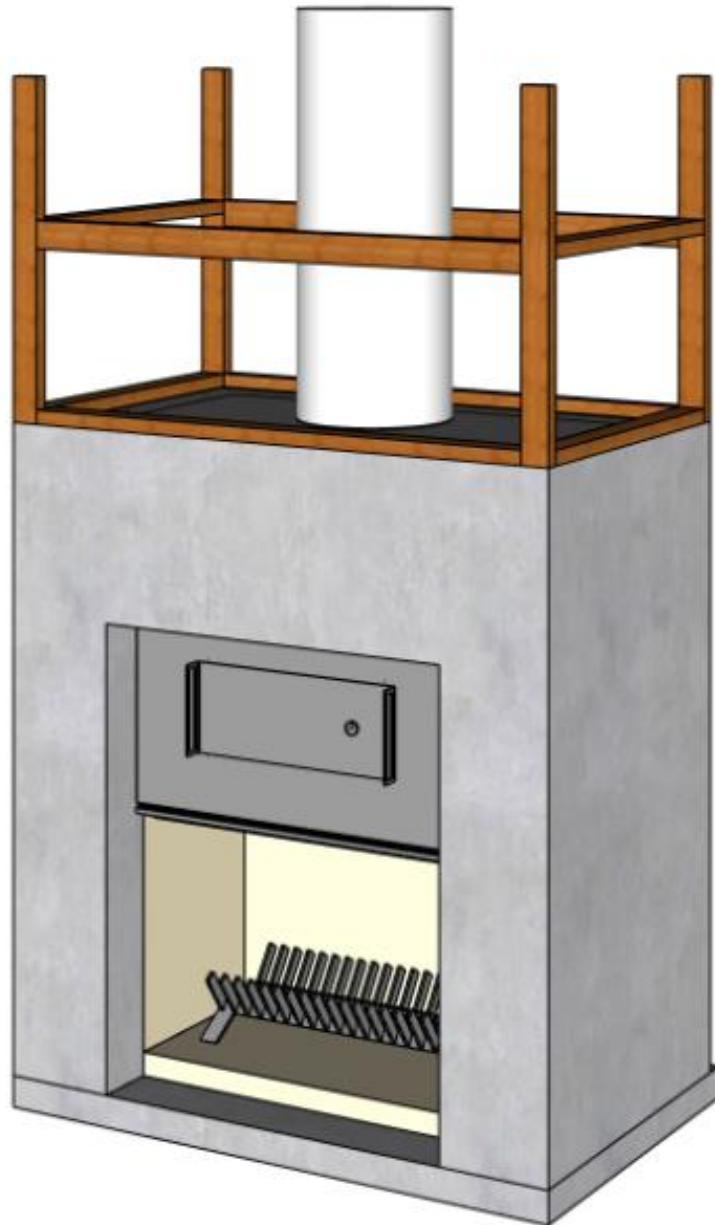

**Fit oven tile.**

**Fit door by reversing door removal process described earlier.**

**Place the grate in the centre of the fire brick cavity.**

**Appliance is now ready for customer-specified outer finishes.**

## **Step 8: Show owner how to operate appliance**

- Following the Operating Instructions on the next page, show the owner how to operate the baffle, and if fitted, the log ignitor.
- If the owner is not available, leave this manual by the appliance.

## OPERATING INSTRUCTIONS

- The WD5 has an integrated baffle, which controls the amount of heat and smoke that enters the cooking area.

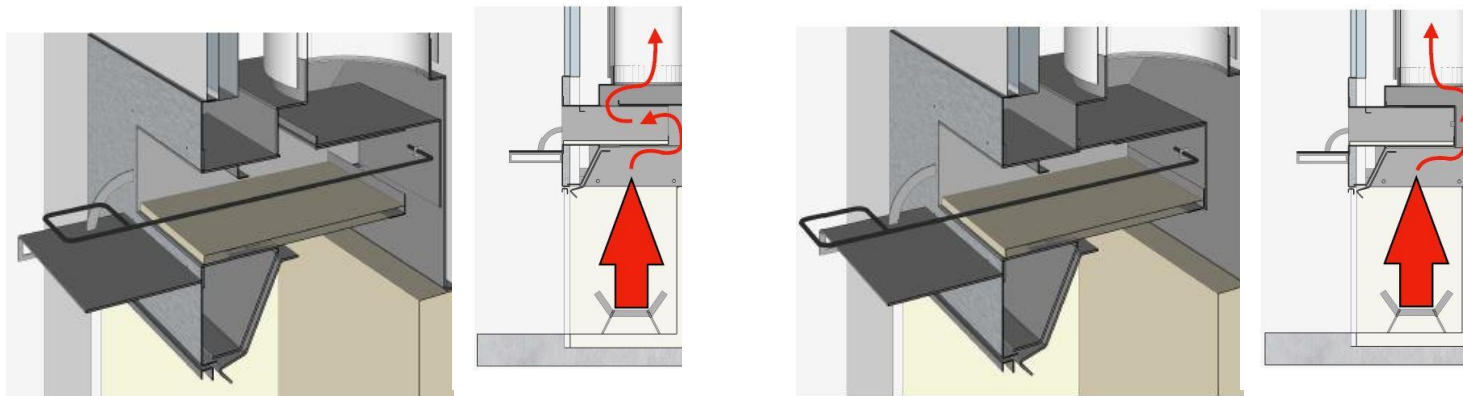
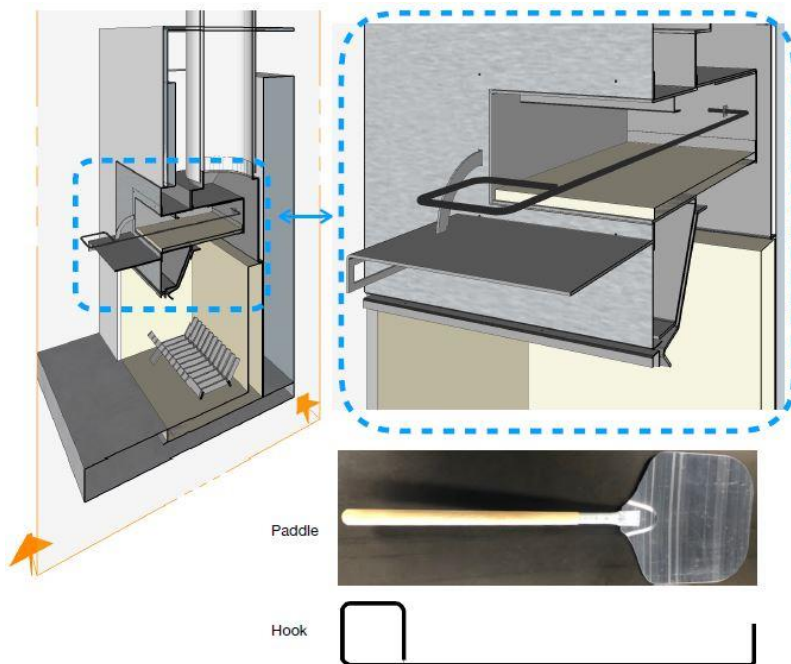

**Push baffle back to allow heat and smoke to enter the cooking area.**

**Pull baffle forwards to stop/adjust heat and smoke entering the cooking area.**

- It is recommended that the baffle is closed (pulled forward) when lighting the fire, as this stops small amounts of ash entering the cooking area. Get the fire going then open the baffle (by pushing it backwards) to heat the cooking area. When the cooking area is hot (allow 30 minutes), close the baffle (pulled forward) and place the food inside. Your personal cooking style may vary.
- Ongoing maintenance.** It is recommended that the flue be swept every year (some insurance companies require this), or more often if required. Fire bricks will deteriorate over time and must be regularly checked for cracking and movement. Repair or replace as required.

## TROUBLESHOOTING

Problem	Probable Cause	Action
Smoke is entering room	<ol style="list-style-type: none"> <li>Poor quality or damp wood</li> <li>Flue damper is closed</li> <li>Draft flowing into or across fire</li> <li>Flue terminates at poor position outside (eg. windy part of roof)</li> <li>A nearby extractor fan is sucking smoke from the fire</li> </ol>	<ol style="list-style-type: none"> <li>Change wood</li> <li>Open flue damper</li> <li>Remove source of draft</li> <li>Reposition flue termination</li> <li>Switch off or reposition extractor fan</li> </ol>
Baffle stuck or won't adjust	Build-up of rust scale	Lightly tap the rear of the baffle to loosen rust

# PRODUCT WARRANTY

**IMPORTANT:** Evidence of original purchase is required for warranty service.

**WARRANTOR:** 'The Fire Dept.' (Landscape Elements Ltd)  
85 Newton Road  
Mount Maunganui  
PO Box 10275, Bayfair, Mount Maunganui

## ELEMENT OF WARRANTY

'The Fire Dept.' warrants to the original retail owner for the duration of this warranty, it's fireboxes, gas burner tray, lighters, (herein after referred to as the Product) to be free from defects in materials and craftsmanship with only the limitations or exclusions set out below.

## WARRANTY

This warranty will be deemed invalid if the Product is;

- (A) Installed by someone other than an authorised Fire Dept agent.
- (B) Not operated appropriately or "over-fired" in a manner resulting in the firebox operating excessively hot.
- (C) Not serviced and maintained by a certified gas fitter every 12 months.
- (D) Damaged by accident, neglect or misuse,
- (E) Repaired by someone other than an authorised Fire Dept repair agent for a defect or malfunction covered by this warranty.
- (F) Modified, altered or used as part of any conversion kits, subassemblies, or any configurations not sold by 'The Fire Dept.'
- (G) The product contains fire bricks and has not been subjected to the recommended first start-up and run-in procedure.
- (H) Used in conjunction with any equipment or parts or as part of a system not manufactured or supplied by 'The Fire Dept.'
- (I) External powder-coating within 200m of the high tide mark and not lightly washed with warm soapy water every three months.

## Indoor appliances (Gas & Wood)

'The Fire Dept.' warrants the mild steel firebox, galvanised steel outer skin and RHS Duragal steel support frame against defective materials and workmanship which would render it unfit for normal domestic use, from the date of purchase by the original consumer, for a period of 5 (five) years. Beyond normal heat-induced staining, tarnishing and mild warping, if a firebox, outer skin or support frame defect occurs, contact 'The Fire Dept.' and the defect will be repaired or replaced at our discretion with all costs covered.

'The Fire Dept.' warrants the SIT Pack (Gas regulator and controller) against defective materials and workmanship which would render it unfit for normal domestic use, from the date of purchase by the original consumer, for a period of 2 (two) years.

Components including fire medium, fans, tiles, glass and glass trim are warranted for a period of 2 (two) years from the date of original purchase, against defective materials and workmanship.

## Outdoor appliances (Gas & Wood)

'The Fire Dept.' warrants the Mild Steel firebox, galvanised steel outer skin and RHS Duragal Steel support frame against defective materials and workmanship which would render it unfit for normal domestic use, from the date of purchase by the original consumer, for a period of 2 (two) years. Beyond normal heat-induced staining, tarnishing and mild warping, if a firebox, outer skin or support frame defect occurs, contact 'The Fire Dept.' and the defect will be repaired or replaced at our discretion with all costs covered.

'The Fire Dept.' warrants the SIT Pack (Gas regulator and controller) against defective materials and workmanship which would render it unfit for normal domestic use, from the date of purchase by the original consumer, for a period of 2 (two) years.

Components including fire medium, fans, tiles, glass and glass trim are warranted for a period of 2 (two) years from the date of original purchase for domestic use, against defective materials and workmanship.

## STATEMENT OF REMEDY

In the event that the Product does not conform to this warranty at any time while this warranty is in effect, the Warrantor, at its discretion, will repair the defect or replace the part and return it to you without charge for parts or service. This warranty does not provide for reimbursement or payment of incidental or consequential damages.

This warranty does not in any way affect your rights under the Consumers Guarantee Act (New Zealand).