

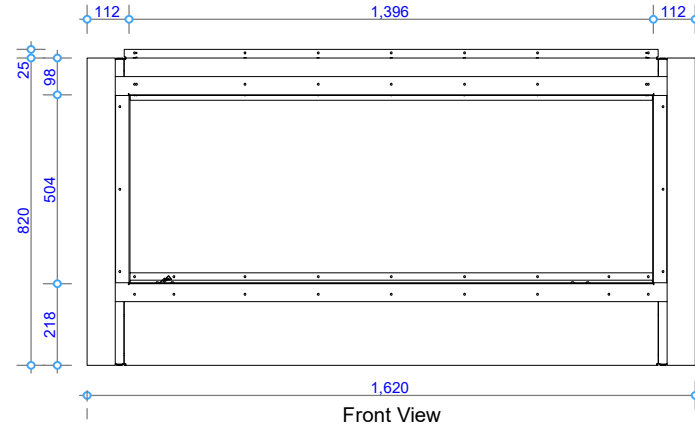

GD6 | 1400
RECESSED BURNER
SPECIFICATIONS

Information in this specification may be subject to change without notice. Please ensure you have the current version before beginning installation.

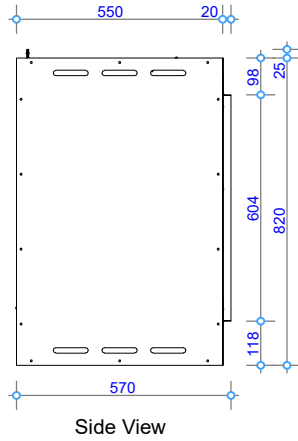
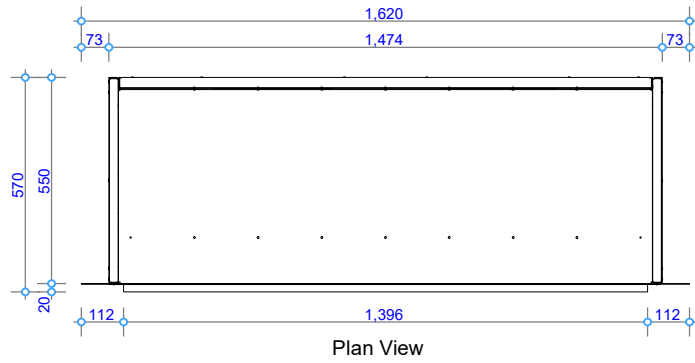

TOLERANCE = +/- 3mm

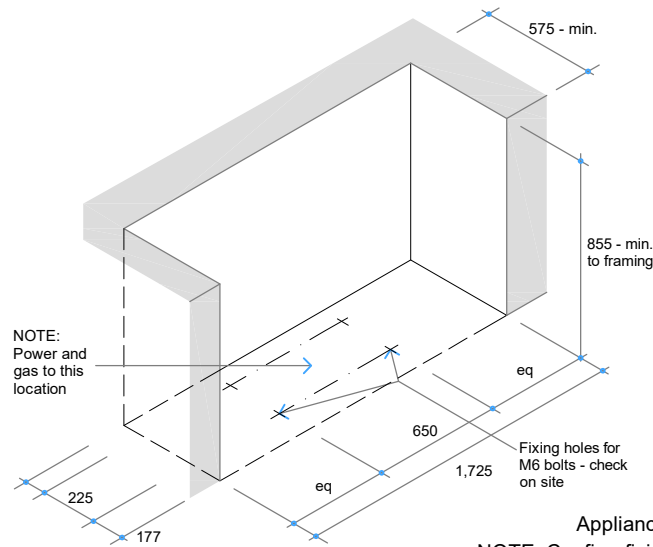

Appliance Installation - Trim Sizes
 NOTE: Confirm fixing holes on site prior to drilling. The cavity (that the fire box is to be installed) must be weather tight and comply with the requirements of the New Zealand Building Codes Clause E2 (External Moisture).

COPYRIGHT©
 THIS DRAWING IS THE PROPERTY
 OF The Fire Dept.

Client: THE FIRE DEPT.		
Product: GD6-1400-Recessed Burner		
Title: FIREBOX DIMENSIONS		
Drawn: LB	Date: 05/05/2020	
Chkd: JW	Date: 08/05/2018	
Appd: JW	Date: 08/05/2018	
Scale:		on A4



Drawing No.	GD6-1400-901RB	Sheet 01 of 04	Revision 2
-------------	-----------------------	----------------	--

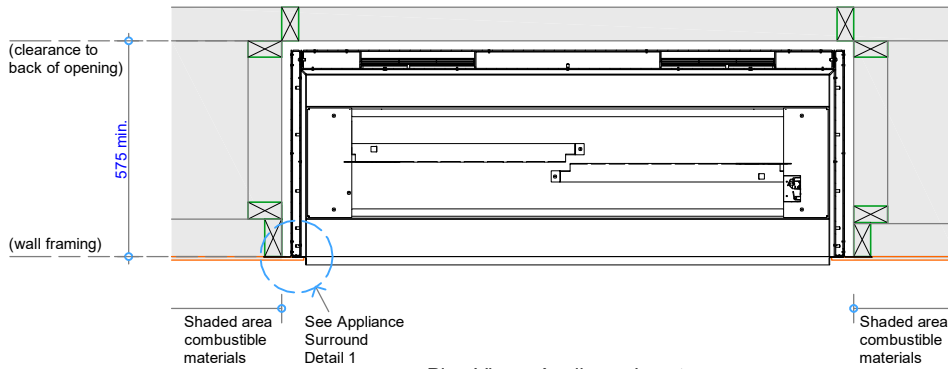

Plan View - Appliance Insert

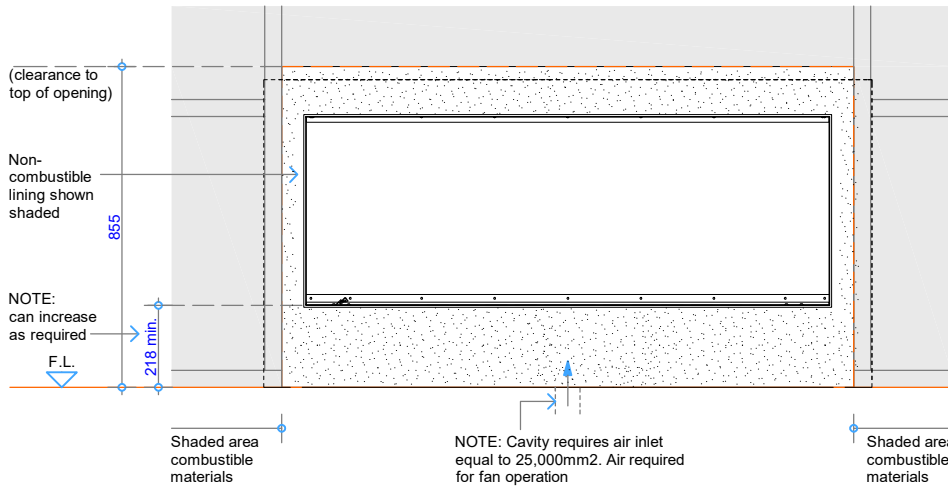

Front View - Appliance Insert

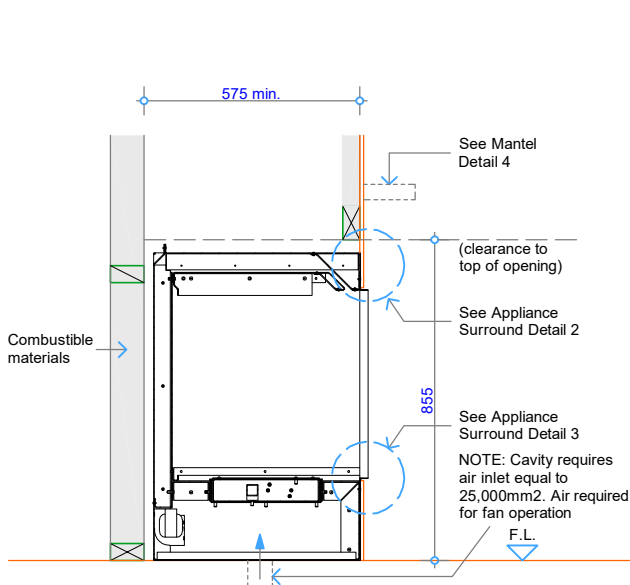

Cross Section - Appliance Insert at Floor Level

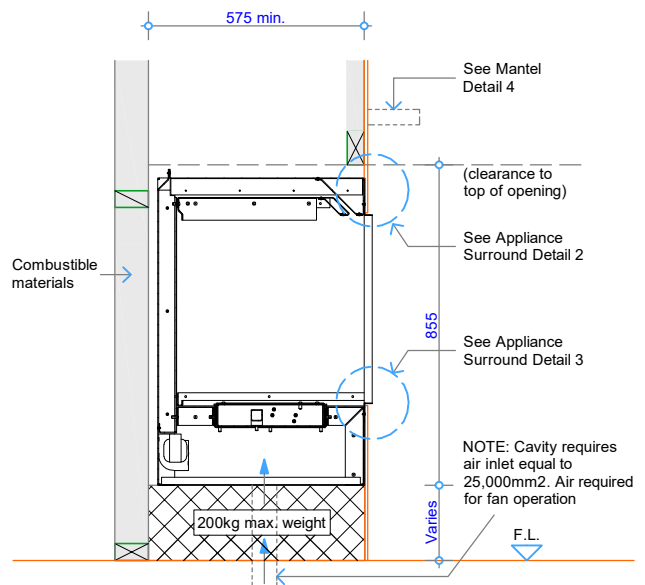

Cross Section - Appliance Insert on Plinth

NOTE: Plinth height can vary to suit

COPYRIGHT ©
 THIS DRAWING IS THE PROPERTY
 OF The Fire Dept.

Client: THE FIRE DEPT.		
Product: GD6-1400-Recessed Burner		
Title: CAVITY CLEARANCES		
Drawn: LB	Date: 04/05/2020	
Chkd: JW	Date: 08/05/2018	
Appd: JW	Date: 08/05/2018	
Scale:		on A4



Drawing No.	GD6-1400-902RB	Sheet 02 of 09	Revision 2
-------------	-----------------------	----------------	--

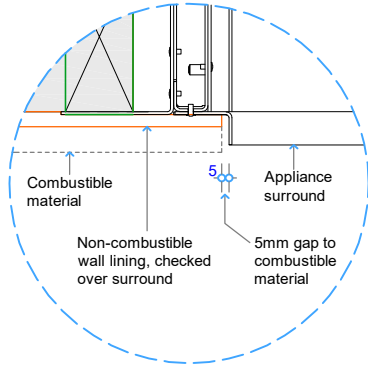

Detail 1 - Plan View Appliance Surround

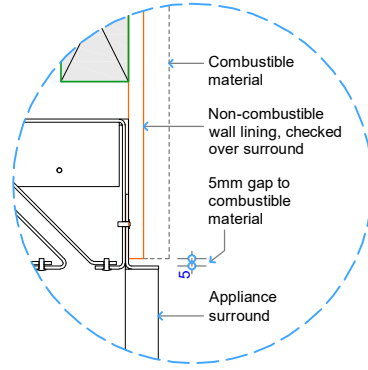

Detail 2 - Top of Appliance to Combustible Materials

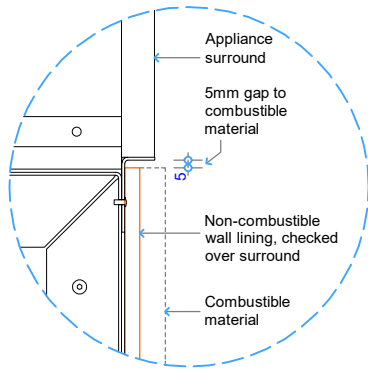

Detail 3 - Bottom of Appliance to Floor

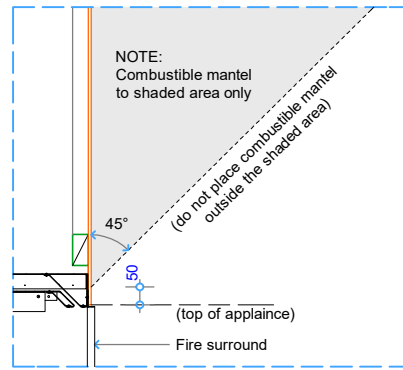

Detail 4 - Top of Appliance to Combustible Mantel

COPYRIGHT ©
 THIS DRAWING IS THE PROPERTY
 OF The Fire Dept.

Client: THE FIRE DEPT.		
Product: GD6-1400-Recessed Burner		
Title: SURROUND DETAILS		
Drawn: LB	Date: 04/05/2020	
Chkd: JW	Date: 08/05/2018	
Appd: JW	Date: 08/05/2018	
Scale:		



Drawing No.	GD6-1400-903RB	Sheet 03 of 04	Revision	1
-------------	-----------------------	----------------	----------	---

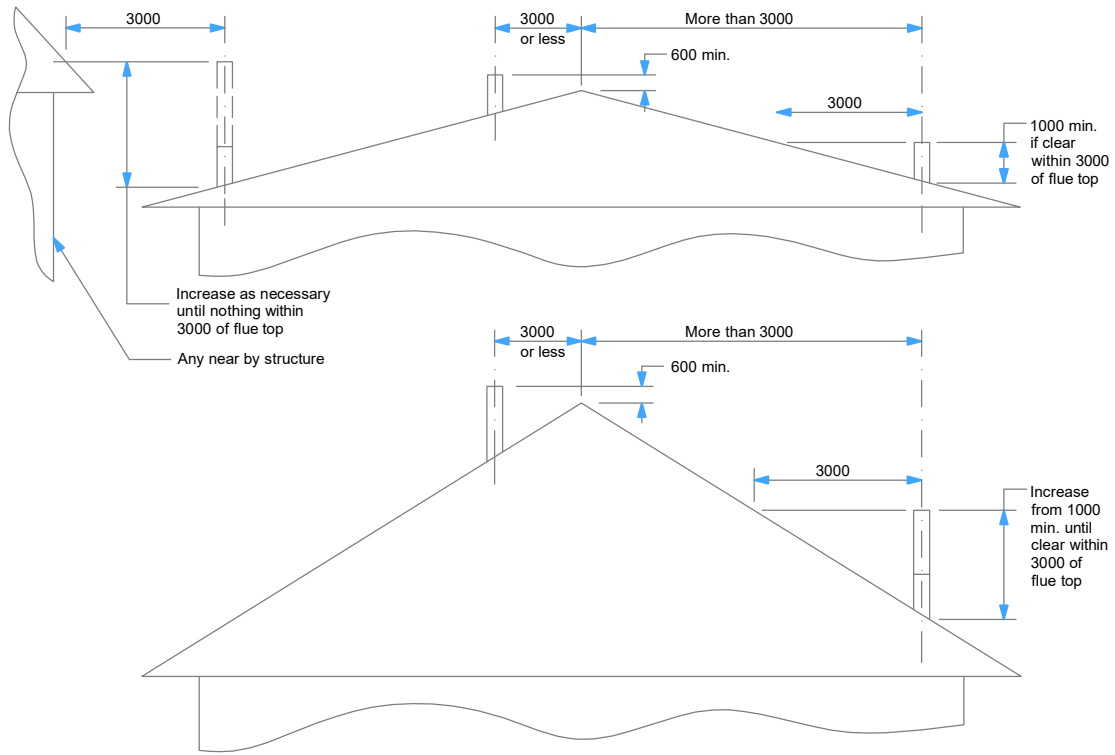

Minimum Height of Flue System Exit
Or as per AS/NZS 5601

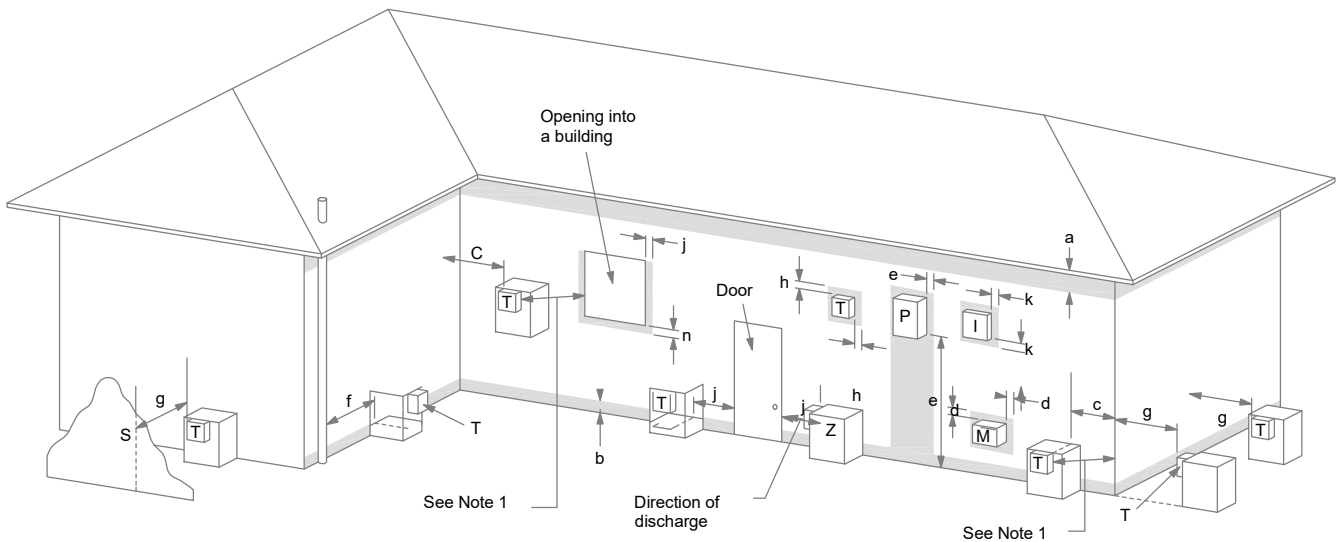

LEGEND:
 I = Mechanical air inlet
 M = Gas meter
 P = Electricity meter or fuse box
 S = Structure
 T = Flue terminal
 Z = Fan-assisted appliance only

a = 200 g = 500
 b = 300 h = 300
 c = 300 j = 300 (at window) & 1500
 d = 1000 (fan-assisted appliance by the door)
 e = 500 k = 1000
 f = 75 n = 500

NOTES:
 1 Where dimensions c, j or k cannot be achieved an equivalent horizontal distance measured diagonally from the nearest discharge point of the terminal to the opening may be deemed by the Technical Regulator to comply.

Shading indicates prohibited area for flue terminals

Location of Flue Terminals of Balanced Flue, Room-Sealed, Fan-Assisted or Outdoor Appliances

NOTE: To be read in conjunction with AS/NZS 5601.1:2013

COPYRIGHT ©
 THIS DRAWING IS THE PROPERTY
 OF The Fire Dept.

Client: THE FIRE DEPT.

Product: GD6-1400-Recessed Burner

Title: FLUE EXIT CLEARANCES

Drawn: LB

Date: 04/05/2020

Chkd: JW

Date: 08/05/2018

Appd: JW

Date: 08/05/2018

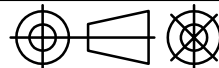

Scale: on A4

THE FIRE DEPT.
HAND CRAFTED FIRES

Drawing No. **GD6-1400-904RB**

Sheet 04 of 04

Revision **2**